

Draft South Derbyshire Design Guide

Design Supplementary Planning Document
May 2017

Draft version 1.2



Contents

EXECUTIVE SUMMARY

Page

Introduction	5
The purpose of this document	
How to use this guide	
Policy context	
Definition of good design	
Design Process	12
Community safety	17
Street design, movement & legibility	23
Diversity and community cohesion	38
Ease of use	43
Local character and pride and visual attractiveness	49
National Forest	61
Neighbouring uses and amenity	68
Cross boundary collaboration	72

Healthy lifestyles	75
Resource use	80
Design Principles (Domestic/residential development)	
Design guidance for Non-domestic development	82
Architectural terminology	91
References	92
Appendices	93
A - Extending your home	94
B – Checklist for a site and contextual analysis	99
C – Relationship between the District Council’s Design Principles (Policy BNE1) and national policies, initiatives and guidance documents	100
D – Lifetime Homes 16 Criteria	102
E - The landscape character of Derbyshire	103
F – Justification of the need to address air pollution	104
G - Historic South Derbyshire	108

Executive Summary

INTRODUCTION

This guide aims to improve the design quality of development in South Derbyshire and further explain the Design Principles set out in the Local Plan Part 1 (Policy BNE1).

HOW TO USE THIS GUIDE

Design Process – this is the place to start and should be taken into account at the beginning of designing a development proposal.

Extending your home (Appendix 1) – this is the only chapter that needs to be referred to regarding householder extensions.

POLICY CONTEXT

The Design Principles within this document are closely aligned with the NPPF and supporting guidance in the PPG.

DESIGN PROCESS

- 1) Starting point – ensure urban design expertise is present and engage in pre-application discussions;
- 2) Assessment;
- 3) Simple vision;
- 4) Involvement;
- 5) Detailed design proposal;
- 6) Application; and
- 7) Implementation.

DESIGN PRINCIPLES

Based on Local Plan Policy BNE1 and relating specifically to domestic development.

COMMUNITY SAFETY

Increase visibility; Define the public and private; Create safe street networks; Encourage people to own, respect and protect.

STREET DESIGN, MOVEMENT AND LEGIBILITY

High quality streets; Design for walkability; Promote cycling; Design for slow speeds; Create a navigable place; Create connected neighbourhoods; Deliver viable public transport routes; Make parking comfortable (amount, size, garages, integral garages, rear courtyards, car parks, cycle parking).

DIVERSITY AND COMMUNITY COHESION

Encourage a sense of belonging and community togetherness; Create diverse places where people can meet, Integrate local centres in to the townscape; Design streets and public open spaces for the whole community.

EASE OF USE

Design places that can be used by all; Design buildings that can be used by all; Consider demographics; Be prepared for change; Make bin storage and collection simple; Create places that are easy to manage.

LOCAL CHARACTER AND PRIDE AND VISUAL ATTRACTIVENESS

Start off on the right foot (undertake a sight and contextual appraisal); Consider all aspects of local character (landscape and topography, history, views and vistas, streets and spaces, urban structure and urban grain, architectural style and detailing) Respect the Existing; Communicate a buildings function; Research new character.

NATIONAL FOREST

Provide green infrastructure on site; Make trees play a leading role; Design continuous green routes; Create high quality gardens; Use timber and planting in construction; Design developments around SUDS; Think specifically about wildlife habitats; Think ahead (phasing, ownership, management and maintenance).

NEIGHBOURING USES AND AMENITY

Consider overlooking and overshadowing; Think about quality of life.

CROSS BOUNDARY COLLABORATION

Create quality urban design guidance; Protect future links; Create connected infrastructure.

HEALTHY LIFESTYLES

Design for physical activity; Create opportunities for contact with nature; Positive social contact; Design for cleaner air

RESOURCE USE

Encourage people to compost household waste; Reduce demand for water, Embrace solutions for sustainable energy and power generation.

DESIGN GUIDANCE FOR NON-DOMESTIC DEVELOPMENT

Using the Design Principles as themes, specific guidance for non-domestic development.

EXTENDING YOUR HOME

Appearance, scale, character and form, position, materials, the effect on neighbours, and access and parking.

Introduction

The purpose of this document

This guide aims to improve the design quality of new development in South Derbyshire. It also further explains the design principles set out in the Local Plan Part 1 (Policy BNE1).

How to use this guide

This guidance should be applied proportionately in relation to the scale of development. It does not aim to provide an exhaustive check list for design, and the Council will use its discretion where certain aspirations are not fully realised. However, all efforts should be made to comply with the guidance in full.

The guide seeks to cover all types of development, from new residential and commercial schemes, to conversions and extensions. Hence, for smaller schemes the following chapters may be less relevant:

- Diversity and community cohesion;
- Cross-boundary collaboration; and
- Healthy lifestyles.

Design Process

This is the place to start and should be taken into account at the very beginning of a proposal for development. This applies to all domestic and non-domestic development, except for 'Extending your home' (see below).

Design Principles

This section expands upon the Design Principles set out in Policy BNE1, providing detailed guidance under these different themes. There are separate sections for domestic and non-domestic developments.

Extending your home (Appendix A)

This is the only chapter that needs to be referred to regarding householder extensions.

Conservation Areas and Listed Buildings

Although the best practice within this guidance is relevant to buildings and settlements with heritage value, more specific guidance can be found in Historic South Derbyshire (Appendix G) and also within the Conservation Area Character Appraisals on the District

Council's website.

Illustrations

The diagrams help to illustrate the text and provide examples. They do not represent 'the' way of applying the guidance. The Council is not recommending a 'one size fits all' approach and encourages innovation.

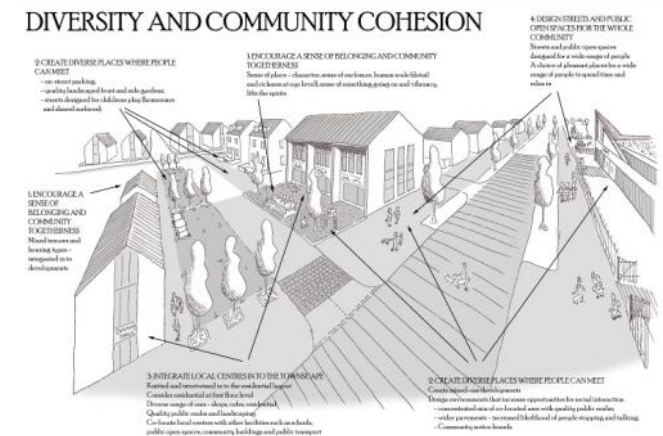

Policy context

Local Plan Policy BNE1 ii)

All proposals for new development will be assessed against the Council's Design SPD.

Sustainability, health, wellbeing, communities, local pride, biodiversity, tourism and economic prosperity can all flourish in well designed, people friendly places. Poorly designed places can, and often do, lead to social, economic and environmental decline.

Local Authorities have a statutory duty under the Planning Act 2008 to encourage good design and the NPPF states that good design is indivisible from good planning. Design is one of the most powerful tools in achieving sustainable development. In working towards global causes, design is also about much smaller scale, personal and intimate factors – people, their everyday lives, health, wellbeing and happiness.

Good design gels together and improves many of the Council's key services, aspirations and statutory responsibilities, addressing large scale issues such as protecting and enhancing the unique character of the District for residents and visitors; attracting new investment; tackling crime, anti-social behaviour, road safety and social exclusion; improving health and wellbeing; and strengthening communities and connecting them together. Smaller scale, but equally important issues include designing out potential problems caused by parking and bin collections.

South Derbyshire District Council adopted their Local Plan Part 1 in June 2016. Policy BNE1 (Design Excellence) sets out a series of Design Principles. This Design SPD links directly to the Principles, using them as chapter headings. This guidance is therefore integrated with the adopted Local Plan.

The table below illustrates how the Design Principles in Policy BNE1 and within this document relate to the NPPF.

SDDC Design Principles	NPPF paragraph number and selected extracts	Other Local Plan Policy relevant to BNE1 (Design Excellence) and selected extracts
<p>Community safety</p>	<p>Paragraphs 58, 69</p> <p><i>'create safe and accessible environments where crime and disorder, and the fear of crime, do not undermine quality of life or community cohesion' (paragraph 58)</i></p>	<p>S3 (Environmental Performance), S6 (Sustainable Access), SD4 (Contaminated Land and Mining Legacy Issues) BNE9 (Advertisements and Visual Pollution), INF2 (Sustainable Transport).</p> <p><i>'The Council will support developers in bringing forward more sustainable homes and commercial properties by supporting the governments drive towards improved housing standards in respect of access, space standards, security, water and external waste storage'. (policy S3)</i></p> <p><i>'support transport measures that address accessibility, safety, amenity health, social and economic needs' (Policy S6).</i></p>
<p>Street design, movement and legibility</p>	<p>Paragraphs 9, 17, 35, 38, 39, 41, 58, 61, 69, 75</p> <p><i>'give priority to pedestrian and cycle movements, and have access to high quality public transport facilities' (paragraph 35)</i></p> <p><i>'minimise conflicts between traffic and cyclists or pedestrians, avoiding street clutter and where appropriate establishing home zones' (paragraph 35)</i></p> <p><i>'key facilities such as primary schools and local shops should be located within walking distance of most properties' (paragraph 38)</i></p> <p><i>'establish a strong sense of place, using streetscapes...to create attractive and comfortable places...'</i> (paragraph 58)</p> <p><i>'safe and accessible developments, containing clear and legible pedestrian routes' (paragraph 69).</i></p>	<p>S6 (Sustainable Access), INF2 (Sustainable Transport), INF6 (Community Facilities)</p> <p><i>'The Council will minimise the need to travel, make the most efficient use of transport infrastructure and services and encourage modal shift away from the private car and road based freight toward walking, cycling, public transport and rail freight...(Policy S6).</i></p> <p><i>'Community facilities should be accessible to all members of the community and be located where there is a choice of travel options. (Policy INF6)</i></p>
<p>Diversity and community cohesion</p>	<p>Paragraphs 9, 17, 38, 47, 50, 69, 70</p> <p><i>'opportunities for meetings between members of the community who might not otherwise come in to contact with each other, including through mixed-use developments, strong neighbourhood centres and active street frontages which bring together those who work, live and play in the vicinity' (paragraph 69)</i></p> <p><i>'plan positively for the provision and use of shared space, community facilities (such as local shops, meeting places, sports venues, cultural buildings, public houses and places of worship) and other local services to enhance the sustainability of communities and residential environments' (paragraph 70)</i></p>	<p>H20 (Housing Balance), INF6 (Community Facilities)</p> <p><i>'the Council will seek to provide a balance of housing that includes a mix of dwelling type, tenure size and density...the Council will also promote a mix of housing that is suitable and adaptable for different groups of people such as single occupiers, people with disabilities, people wanting to build their own homes and the aging population of the District'. (Policy H20).</i></p> <p><i>The council will 'require that development that increases the demand for community facilities and services either provide the required community facilities as part of the development or makes appropriate contributions towards providing new facilities or improving existing facilities' (Policy INF6).</i></p>

<p>Ease of use</p>	<p>Paragraphs 35, 39, 57, 58, 69</p> <p><i>'consider the needs of people with disabilities by all modes of transport' (paragraph 35)</i></p> <p><i>'plan positively for the achievement of high quality and inclusive design for all development' (paragraph 57)</i></p> <p><i>'will function well and add to the overall quality of the area, not just for the short term but over the lifetime of the development' (paragraph 58)</i></p>	<p>S3 (Environmental Performance), H20 (Housing Balance), INF2 (Sustainable Transport) INF4 (Transport Infrastructure Improvement Schemes)</p> <p><i>'The Council will support developers in bringing forward more sustainable homes and commercial properties by supporting the governments drive towards improved housing standards in respect of access, space standards, security, water and external waste storage'. (policy S3)</i></p> <p><i>'the Council will also promote a mix of housing that is suitable and adaptable for different groups of people such as single occupiers, people with disabilities, people wanting to build their own homes and the aging population of the District'. (Policy H20)</i></p> <p><i>'regard shall be had to providing for the needs of pedestrians, cyclists and people with impaired mobility. (Policy INF4)</i></p>
<p>Local character and pride</p>	<p>Paragraphs 9, 10, 17, 56, 58, 59, 60, 61, 64, 109</p> <p><i>'take account of the different roles and character of different areas' (paragraph 17)</i></p> <p><i>'respond to local character and history, and reflect the identity of local surroundings and materials, while not preventing or discouraging appropriate innovation' (paragraph 58)</i></p> <p><i>'planning policies and decisions should not attempt to impose architectural styles or particular tastes...It is, however, proper to seek to promote or reinforce local distinctiveness' (paragraph 60)</i></p> <p><i>'Permission should be refused for development of poor design that fails to take the opportunities available for improving the character and quality of an area and the way it functions' (paragraph 64)</i></p> <p><i>'protecting and enhancing valued landscapes, geological conservation and soils' (paragraph 109)</i></p>	<p>E7 (Rural Development), BNE2 (Heritage Assets) BNE4 (Landscape Character and Local Distinctive), BNE9 (Advertisements and Visual Pollution), BNE10 (Heritage)</p> <p><i>'Development that affects any heritage asset will need to ensure that development proposals contribute positively to the character of the built, historic and natural environment' (Policy BNE2)</i></p>

<p>Visual attractiveness</p>	<p>Paragraphs 9, 17, 55, 58, 59, 63, 64, 118</p> <p><i>'are visually attractive as a result of good architecture and appropriate landscaping' (paragraph 58)</i></p> <p><i>'always seek to secure high quality design...for all existing and future occupants of land and buildings' (paragraph 17)</i></p> <p><i>'establish a strong sense of place, using streetscapes and buildings to create attractive and comfortable places...'</i> (paragraph 58)</p> <p><i>'are visually attractive as a result of good architecture and appropriate landscaping' (paragraph 58)</i></p> <p><i>'In determining applications, great weight should be given to outstanding or innovative designs which help raise the standard of design more generally in the area' (paragraph 63)</i></p> <p><i>'Permission should be refused for development of poor design that fails to take the opportunities available for improving the character and quality of an area and the way it functions' (paragraph 64)</i></p>	<p>E7 (Rural Development), BNE2 (Heritage Assets) BNE4 (Landscape Character and Local Distinctiveness), BNE9 (Advertisements and Visual Pollution), BNE10 (Heritage)</p> <p><i>The character, local distinctiveness, and quality of South Derbyshire's landscape and soilscape will be protected and enhanced through the careful design and sensitive implementation of new development' (Policy BNE4)</i></p> <p><i>Development that affects any heritage asset will need to ensure that development proposals contribute positively to the character of the built, historic and natural environment' (Policy BNE2)</i></p>
<p>National Forest</p>	<p>Paragraphs 9, 17, 58, 60, 109, 117, 118, 123, 125</p> <p><i>'moving from a net loss of bio-diversity to achieving net gains for nature' (paragraph 9)</i></p> <p><i>'support the transition to a low carbon future in a changing climate' (paragraph 17)</i></p> <p><i>'contribute to conserving and enhancing the natural environment and reducing pollution' (paragraph 17)</i></p> <p><i>'take account of and support local strategies to improve health, social and cultural wellbeing for all' (paragraph 17)</i></p> <p><i>'respond to local character and history, and reflect the identity of local surroundings and materials' (paragraph 58)</i></p> <p><i>'contribute to and enhance the natural and local environment by: protecting and enhancing valued landscapes...recognising the wider benefits of ecosystem services...providing net gains in biodiversity...establishing coherent ecological networks that are more resilient to current and future pressures' (paragraph 109)</i></p> <p><i>'plan for biodiversity at a landscape-scale across local authority boundaries' (paragraph 117)</i></p> <p><i>'when determining planning applications, local planning authorities should aim to conserve and enhance biodiversity' (paragraph 118)</i></p>	<p>INF7 (Green Infrastructure) INF8 (The National Forest) BNE3 (Biodiversity), BNE4 (Landscape Character and Local Distinctiveness), BNE7 (Trees, Woodland and Hedgerows)</p> <p><i>'Within the National Forest new development should ensure that the siting and scale of the proposed development is appropriately related to its setting within the Forest and the proposed development respects and does not adversely affect the character and appearance of the wider countryside. (Policy INF8)</i></p> <p><i>'Developers will be expected to retain key valued landscape components such as mature trees, established hedgerows and topographical features within development sites unless it can be demonstrated that the loss of features will not give rise to unacceptable effects on local landscape character. Development that will have an unacceptable impact on landscape character (including historic character), visual amenity and sensitivity and cannot be satisfactorily mitigated will not be permitted'. (PolicyBNE4).</i></p>

<p>Neighbouring uses and amenity</p>	<p>Paragraphs 17, 123, 124, 125</p> <p><i>'always seek to secure high quality design and a good standard of amenity for all existing and future occupants of land and buildings' (paragraph 17)</i></p> <p><i>'planning policies and decisions should aim to: avoid noise from giving rise to significant adverse impacts on health and quality of life as a result of new development' (paragraph 123)</i></p>	<p>SD1 (Amenity and Environmental Quality)</p> <p><i>The Council will support development that does not lead to adverse impacts on the environment or amenity of existing and future occupiers within or around proposed developments (Policy SD1)</i></p>
<p>Cross boundary collaboration</p>	<p>Paragraphs 17, 31, 70, 117, 178, 179, 180, 181</p> <p><i>'Local authorities should work with neighbouring authorities and transport providers to develop strategies for the provision of viable infrastructure necessary to support sustainable development...'</i> (paragraph 31)</p> <p><i>'plan for biodiversity at a landscape-scale across local authority boundaries' (paragraph 117)</i></p> <p><i>"Public bodies have a duty to cooperate on planning issues that cross administrative boundaries..." (paragraph 178)</i></p>	<p>INF1 (Infrastructure and Developer Contributions), INF7 (Green Infrastructure)</p> <p><i>'New development that is otherwise in conformity with the Local Plan but generates a requirement for infrastructure will normally be permitted if the necessary on and off-site infrastructure required to support and mitigate the impact of that development is either already in place, or there is a reliable mechanism in place to ensure that it will be delivered in the right place, at the right time and to the standard required by the Council and its partners'.</i></p>
<p>Healthy Lifestyles</p>	<p>Paragraphs 7, 8, 9, 17, 38, 69, 70, 73, 74, 171, 178</p> <p><i>'supporting strong, vibrant and healthy communities' (paragraph 7)</i></p> <p><i>'key facilities such as primary schools and local shops should be located within walking distance of most properties' (paragraph 38)</i></p> <p><i>'The planning system can play an important role in facilitating social interaction and creating healthy, inclusive communities.'</i> (paragraph 69)</p> <p><i>'Access to high quality open spaces and opportunities for sport and recreation can make an important contribution to the health and well-being of communities.'</i> (paragraph 73)</p>	<p>INF2 (Sustainable Transport), INF6 Community Facilities, INF9 Open Space, Sport and Recreation.</p> <p><i>'the Council will work with partners to provide sufficient high quality green space and recreation facilities including sports pitches and built facilities, allotments, woodland creation, cemeteries and publicly accessible natural green space to meet the needs of new residential development and, where possible, to meet the needs of the existing population'. (Policy INF9)</i></p>

<p>Resource Use</p>	<p>Paragraphs 7, 17, 94, 95, 97</p> <p><i>'use natural resources prudently, minimise waste and pollution, and mitigate and adapt to climate change...'</i> (paragraph 7)</p> <p><i>'support the transition to a low carbon future in a changing climate, taking full account of flood risk and coastal change, and encourage the reuse of existing resources, including conversion of existing buildings, and encourage the use of renewable resources (for example, by the development of renewable energy)</i> (paragraph 17)</p> <p><i>'Local planning authorities should adopt proactive strategies to mitigate and adapt to climate change, taking full account of flood risk, coastal change and water supply and demand considerations.'</i> (paragraph 94)</p>	<p>SD1 (Sustainable Growth Strategy), S3 (Environmental Performance), SD3 (Sustainable Water Supply, Drainage and Sewerage), SD4 (Contaminated Land and Mining Legacy Issues), SD5 (Minerals Safeguarding), SD6 Sustainable Energy and Power, BNE4 (Landscape Character and Local Distinctive) and Policy INF2 (Sustainable Transport).</p> <p><i>The Council will support developers in bringing forward more sustainable homes and commercial properties by supporting the governments drive towards improved housing standards in respect of access, space standards, security, water and external waste storage'. (Policy S3)</i></p> <p><i>'Supporting activities by the Water Companies to reduce demand for water and in turn suppress sewerage and discharge effluent volumes by ensuring that water consumption is no more than 110 litres per person per day' (Policy SD3)</i></p> <p><i>'The Council will seek to minimise the need to travel and encourage modal shift away from private car and road based freight toward walking, cycling, public transport and rail freight'.</i></p> <p><i>'Development should include appropriate car parking provision having the regard to the need to encourage the use of low emission vehicles'</i></p>
----------------------------	---	---

Design Process summary

Tick

1: Starting Point

 Developers preparing planning applications should ideally make sure that an urban designer has been involved. The design team should have the right skills and approach.

Pre-application discussions – these should begin at this stage and continue through to stage 6, working collaboratively with the Council and other stakeholders.

2: Assessment

 **An on-site meeting** allows all parties to understand and experience the site and its context together, and helps mutual agreement to be reached.

A thorough **site and contextual analysis** should be undertaken before any detailed designs are prepared. Refer to Appendix B and the ‘Consider all aspects of local character’ section for a checklist for what to consider, proportionate to the type and scale of development.

3: Simple Vision

 In order to guide the design and create a distinctive and site specific development – a simple **vision** should be produced along with an accompanying concept plan. The vision should be constantly referred to as the design progresses. The final design should resemble this vision.

4: Involvement

 Interested parties and the community can all provide invaluable input into the emerging designs. Local knowledge can bring important issues to light that may otherwise have been overlooked. Developers are encouraged to undertake **public consultation** early on in the design process.

5: Detailed design proposal

 Once the above steps have been taken, the development team’s urban designer and design team should be well placed to create more detailed proposals. If necessary, a design review can be undertaken at this stage.

6: Application stage

 Submission of a well-researched, grounded and justified development proposal, accompanied by a Design and Access Statement drawing together the above process into a single point of reference.

7: Implementation

Planning conditions will be used where necessary in order to ensure that design quality is not lost during the construction stage and later on, during the use or occupation of the development.

Design Process

1: Starting Point

Developers preparing planning applications should ideally make sure that an urban designer has been involved. The design team should have the right skills and approach.

Pre-application discussions

Throughout stages 1-5, the applicant should work collaboratively with the Council and other parties such as the highway authority or lead flood authority, and engage early in pre-application discussions.

2: Assessment

On-site meeting

Early on in the design process, it can be very helpful for the development team and their urban designer/s to meet on-site with the relevant persons at the Council, including the design officer.

This allows all parties to understand

and experience the site and its context together and helps mutual agreement to be reached.

Site analysis

A thorough site and contextual analysis should be undertaken before any detailed designs are produced.

See Appendix B and also the 'Consider all aspects of local character' section for a checklist of what to consider when undertaking a site and contextual appraisal. Assessments should be proportionate to the type, scale and sensitivity of development.

This is also a good time to involve specialist consultees, such as the County Highways Authority and drainage engineers, who may influence major elements of the site. This can ensure that the design vision is not lost when the scheme is assessed prior to construction under other statutory controls.

Where relevant, the Council's housing department should also be involved at

this early stage, so that key factors can be established, such as the percentage of affordable housing, tenure and mix of housing.

3: Simple Vision

In order to guide the design and create a distinctive and site-specific development, a simple **vision** should be produced. A concept plan should also accompany this vision, setting out the broad layout and key elements that will achieve the vision.

The vision should be constantly referred to as the design progresses. The final design should resemble this vision.

The vision should include a headline statement (see examples below) and

Local Plan Policy BNE1 iii)

The Council will decide which development proposals should be taken to a formal panel for design review.

also some basic information about how this would be achieved.

Example 1

“To create a development that knits in to the Victorian suburbs – with predominantly terraced properties set forward on plots that follow the rhythm and repetition of the existing terraces”

Example 2

“To ensure that the characterless urban sprawl does not continue by creating a contemporary new neighbourhood that leaves a legacy of 21st Century architecture for future generations. Quality open spaces, homezones and networks of green routes and watercourses will encourage active lifestyles for all and allow wildlife to flourish.”

Example 3

“The proposed development will bring a new character area to the edge of the town, creating an organic village layout around existing and new landscape features. Traditionally detailed properties and streets will wind through the development in order to create the rural charm of a South Derbyshire village”

Design Codes

For large residential developments or where a site is likely to be delivered in phases or by multiple developers, a design code can be helpful in adding more detail to the character vision. This should set rules for certain streets

and zones of the development.

Development Briefs

For some development sites, such as town centre locations or small sites in sensitive areas; a development brief can be helpful, providing an analysis and history of the site and some aspirations, guidelines and rules to follow.

Urban design frameworks or masterplans can be used where appropriate, particularly across authority boundaries (see the cross boundary collaboration section).

4: Involvement

As designs start to develop, interested parties and the community can all provide invaluable input into the emerging designs. Local knowledge can bring important issues to light that may otherwise have been overlooked. Developers are encouraged to undertake public consultation early on in the design process (as outlined in paragraphs 188 & 189 of the NPPF).

5: Detailed design proposal

Once the above steps have been taken, the urban designer and design team should be well placed to create more detailed proposals. If necessary, a formal design review should be undertaken at this stage, and the Council will advise whether this is required.

6: Application stage

Full Applications:

The above stages should result in the submission of a well-researched, grounded and justified development proposal.

Formal responses from statutory consultees may create a need for further revisions at this stage, but the character vision should remain true throughout any changes.

Local Plan Policy BNE1

All new development will be expected to be well designed, embrace the principles of sustainable development, encourage healthy lifestyles and enhance people's quality of life by adhering to the Design Principles below.

Outline Applications:

All of the stages above still apply to outline applications. The outline application stage can be key in fixing certain elements to ensure the design does not lose its way at reserved matters stage.

A **vision statement** is very helpful at this stage.

The proposed character of the scheme should be set out. This should include the urban form (for example: whether tight knit Victorian terraces or an organic rural village layout is appropriate, or the street hierarchy and proximity of built form to it).

Fixing elements such as services and facilities, connections, Sustainable Drainage Systems (SuDS), open space size and locations, wildlife areas, tree-lined avenues, trees and hedgerows to be retained can also be very helpful.

Design and Access Statement (DAS):

Although statutory requirements have changed, a DAS is still helpful in illustrating that the stages of this design process have been followed and for showing that the development meets the design principles.

7: Implementation

The Council encourages developers to submit as much detail and information as possible, rather than leaving these details for approval later under conditions. Such detail might include the choice of materials, detailing to eaves, verges and openings, manner of enclosure to public and private spaces, bin collection and storage, and landscaping.

Adoption of roads, SuDS and spaces

The relevant authority should ideally be on board with the design approach

and philosophy early on in the design process. This helps to ensure that the design vision and important character-enhancing details are not eroded by other statutory requirements, and that such areas are suitable for adoption and long term maintenance.

In addition housebuilders can get a 100% discount on the sewerage infrastructure charge where there is no surface water connection or a 75% reduction in the infrastructure charge where a connection is via a SuDS. Further information on this discount scheme can be viewed on Severn Trent's website at:

<https://www.stwater.co.uk/building-and-developing/regulations-and-forms/application-forms-and-guidance/infrastructure-charges/>

Design Principles

The following Design Principles will be used by the Council to structure discussions about design and assess the design quality of new development.

Developers are expected to meet the requirements of all relevant Design Principles and make a robust justification if they are not able to do so.

The Council will also use Building for Life 12¹⁹ (or any subsequent versions) as a design tool with the aim of encouraging schemes to achieve the Built for Life quality mark or the Built for Life 'outstanding' award (or subsequent versions of these quality marks). Please see the Building for Life website for more information www.builtforlifehomes.org

The table in Appendix C demonstrates that the District Council's Design Principles (Policy BNE1) are robustly supported by national planning policies, initiatives and design guidance documents.

Community safety

Street design, movement & legibility

Diversity and community cohesion

Ease of use

Local character and pride and visual attractiveness

National Forest

Neighbouring uses and amenity

Cross boundary collaboration

Healthy lifestyles

Resource use

Tick



Community Safety

Local Plan Policy BNE1: a) Community Safety

New development should be designed to ensure that people feel comfortable and safe by minimising opportunities for crime and anti-social behaviour, providing good natural surveillance and appropriate demarcations between public and private areas;

Background

Section 17 of the Crime and Disorder Act 1998 requires all local authorities to exercise their functions with due regard to their likely effect on crime and disorder, and to do all they reasonably can to prevent crime and disorder.¹

For larger schemes or as appropriate, the Council consults the Crime Prevention Design Advisor and takes into account their comments when assessing applications for planning permission.

The perception of safety or danger doesn't always relate directly to actual incidence of crime. People feel

comfortable and confident using areas with good visibility and effective lighting, where they feel they can be seen and heard by other people.

Thoughtfully designed places are more user-friendly and are typically used and enjoyed by a wider variety of people, enhancing everyone's sense of well-being and freedom to use streets and spaces.

One of the most effective measures for community safety and crime prevention is the creation of lively, lived-in urban areas and public spaces which are easy to overlook and oversee.

Please also see the interactive secure by design tool: <http://interactive.securedbydesign.com/>

Key Actions

1: INCREASE VISIBILITY

Putting 'eyes upon the street' at all times of the day and night can help people feel comfortable and safe whilst also deterring crime and anti-social behaviour. Key ways to achieve this are:

- Active* frontages – making buildings front onto the public realm;
- Avoiding windowless elevations and blank walls adjacent to public spaces (including window graphics and adverts that block visibility);
- Ensuring that buildings turn corners well – all elevations fronting the street to have active* windows;

- Human presence in streets and spaces – for example: on-street parking; larger front gardens; minor residential streets designed for play; wider pavements and attractive walking and cycling routes; mixed uses (see below);
- Mixing uses, particularly at ground level, adding vitality at different time of the day and night and over time (also see the ‘Diversity and Community Cohesion’ section);
- Mixing dwelling types and tenures, enabling greater potential for homes to be occupied throughout the day (and also increased community interaction).



Active frontages in Castleton Park , Church Gresley

* “The word ‘active’ in this sense means rooms in building elevations from which there is direct and regular visual connection between the room and the street or parking court. Such visual connection can be expected from rooms such as kitchens and living rooms, but not from more private rooms, such as bedrooms and bathrooms” (Secured by Design Homes 2016: Version 1, February 2016 – Official Police Security Initiative)

Think carefully about planting

Planting should not impede the opportunity for natural surveillance and must avoid the creation of potential hiding places. As a general recommendation, where good visibility is needed, shrubs should be selected to have a mature growth height of approximately 1 metre or under and trees should ideally have no foliage, epicormic growth or lower branches below 2 metres.

Create overlooked parking

The 'Street Design, Movement and Legibility' chapter covers parking design in more detail and recommends a range of parking solutions that complement the street scene. With regard to community safety, parking should be located in places where people can see their own car.

Rear car parking courtyards are discouraged for the following reasons:

- They introduce access to the vulnerable rear elevations of dwellings where the majority of burglary is perpetrated;
- In private developments, such areas are often left unlit which

increases the fear of crime;

- Un-gated courtyards provide areas of concealment which can encourage anti-social behaviour.

Where rear car parking courtyards are considered absolutely necessary they should be overlooked by active* windows and ideally not serve more than five properties (so that residents have a better chance of knowing who else should be using the space).

Lighting

Streets, spaces and parking areas should be well lit. Low-level and architectural lighting can cast a less austere light and make places feel more comfortable and welcoming, for example; bollard lighting and up-lighting trees and buildings.



Architectural lighting on the Delph public square, Swadlincote

2: DEFINE THE PUBLIC AND PRIVATE

Clear demarcation between public and private spaces

This ensures that people know exactly what private space is (and either keep off it or have a sense of ownership and pride for it if they are the owner/occupier). Land that is not clearly private can get neglected by the owner/occupier and/or be used inappropriately by members of the public.

- Front (and side) boundary treatments can take the form of low walls, railings and robust hedge species (typically no higher than 1m to allow the property to be visible from the street and ensure highway safety is not compromised). They help create defensible space for the owner/occupier and make it clear to the public that the land behind is private. They can also add character to the streetscape (see 'Local Character and Pride' section).
- Minor streets and private drives can be marked as being private/semi-private by features such as rumble strips, change of road surface (by colour or texture), pillars, brick piers or narrowing of

the carriageway. This helps to define the defensible space, psychologically giving the impression that the area beyond is private.



Forest Grange, William Nadin Way, Swadlincote



Alexandra Road, Swadlincote

3: CREATE SAFE STREET NETWORKS

Layouts

In order to maximise street surveillance and help to reduce crime and anti-social behaviour, pedestrians, cyclists and vehicles should ideally share the same network of routes.

Street networks should be permeable, integrated and easy to understand, avoiding too many cul-de-sacs.

Pedestrian-only routes should be avoided (apart from in rural contexts, parks or green corridors for example).

Public access to the rear or side of dwellings should be kept to a minimum and designed out (except for corner turning properties).

If private access points are essential to give access to the rear of properties, they must be gated at the point of origin (entrance point closest to the street) with a lockable, sprung closing gate and shared key.

4: ENCOURAGE PEOPLE TO OWN, RESPECT AND PROTECT

Design in 'territoriality' and community involvement. When people view public space as their own, they begin to take responsibility for it. Clear-cut (character) areas/territories can help to create a community sense of ownership and mutual protection.

For example, if a street has a very strong unique character residents can often feel like custodians of the street and that they are part of something. This can lead to a stronger sense of community and increased social interaction, along with an increased chance of people looking out for one another.

Developments should have a strong character so that people can feel that they belong to something. Larger developments should have areas within them that feel distinctly different, so that people can feel part of an area or street.



Rose Hill, Woodville, Swadlincote

COMMUNITY SAFETY

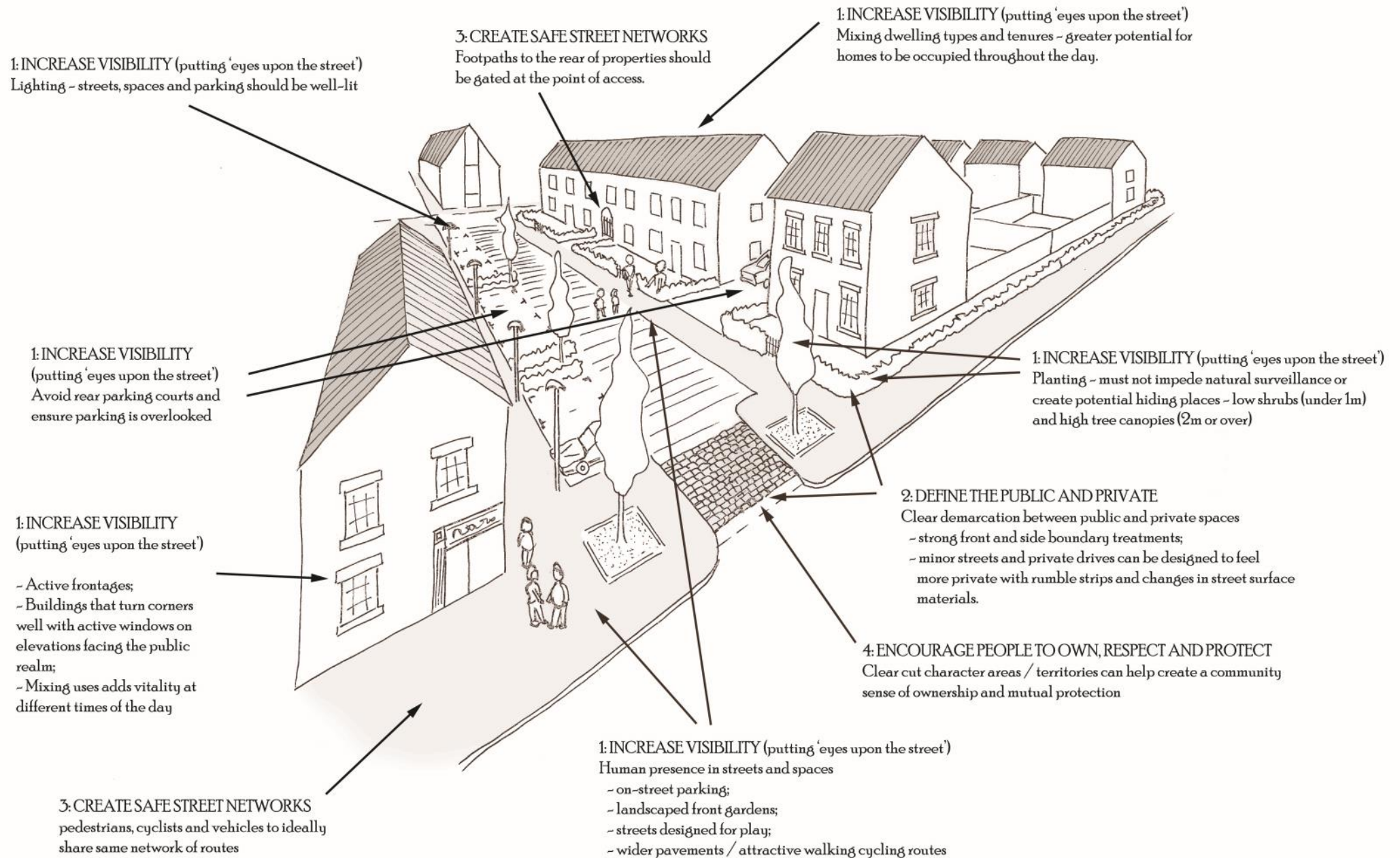

Street design, movement and legibility

BNE1 b) Street design, movement and legibility

Streets should be designed to relate to their context, with a balance being struck between place-making needs and vehicle movement needs. Streets should be attractive, pedestrian and cycle friendly and meet the needs of all users. New development should be easy to find your way around, have a clear hierarchy of streets and take advantage of available opportunities for connections to

Background

The Department for Transport in its Local Transport Notes (1/08² and 1/11³) and the Manual for Streets documents (2007⁴ and 2010⁵) advocate the need for a flexible and balanced approach to be taken towards highway design. They clearly state that streets should be designed to be functional, whilst also considering the visual quality of the

streetscape.

This national guidance also highlights that many locations, particularly residential areas, have much greater place making needs than vehicle movement needs and should be designed accordingly – placing the needs of pedestrians and cyclists ahead of vehicles. These streets form the surroundings within which people live, work and spend leisure time, and thus a different design philosophy is required.

The implementation of this guidance requires collaborative working between planners, urban designers, landscape architects and highway designers.

If walking and cycling routes are attractive, direct, safe, comfortable and pleasant to use, easy to understand and connected together, there are multiple benefits for people's quality of life that link into many other design principles and policy objectives, for example:

- Healthy lifestyles – increased walking and cycling trips reduces car trips, which improves air quality. Active travel such as

walking and cycling improves people's physical and mental health, and increases the numbers of people on the street, making neighbourhoods feel safer and more vibrant and increases social interaction;

- Public transport – safe, direct, attractive and quick walking routes to public transport increases the likelihood of people using the services;
- The needs of an ageing society are better catered for as people feel more confident and able to walk or cycle without the threat of difficult roads to cross, fast moving traffic or the fear of crime on empty streets;
- Vehicle speeds are reduced and drivers are more aware of pedestrians and cyclists.

Streets should be designed so that they are appropriate for their context, surroundings and place in the wider hierarchy of streets. They should not always be uniform and they should

respond and relate to built form and landscape.

The Council strongly recommends that proposals for new development follow a Manual for Streets approach. Reference should also be made to guidance produced jointly by local County Councils, such as the 6C's Design Guide⁶.

Key Actions

1: CREATE HIGH QUALITY STREETS

In preparing development proposals, it is often the case that the large majority of time and effort is spent on designing buildings. The design of streets can be neglected, with designers resorting to standard, uniform dimensions and materials that meet the requirements necessary for the highway authority to adopt the street.

The Council strongly encourages developers to invest time and resources in designing attractive streetscapes.

This could include, for example:

- Streets that respond to their historic or locally distinctive

context (see the 'Character' section);

- Tree-lined avenues;
- Feature trees within the streetscape;
- Mews – narrow, intimate streets or courtyards often with shared surfaces;
- Lanes – rural character with level or shared surfaces, often with grass verge or landscaping abutting the carriageway (i.e. a country lane);
- Home Zones – designed as places for people, rather than traffic. Usually with shared surfaces and with clearly marked entry and exit points, and ideally officially designated;
- Shared surfaces³ - pedestrians and vehicles share the same street space, often paved with alternative materials (see below);
- Level surfaces³ – defined pavements for pedestrians, but low kerb heights and alternative materials – creating a calmed and more attractive streetscape;
- Wider pavements (3m or over) in key areas where they are needed (e.g. close to schools) or where they enhance the setting

of buildings or spaces;

- Feature spaces such as squares and village greens – to create focal points within the streetscape;
- High quality street surface materials such as block or tegula paving, Staffordshire blue clay pavements and granite setts.
- Higher quality kerb stones, such as conservation (textured) kerbs used where appropriate;
- Quality materials at the fronts of properties – private frontage materials are publicly visible and impact on the streetscape. Bland paving slabs on pathways to front doors should be avoided and streetscape quality can be raised significantly with high quality materials such as Staffordshire blue pavements.
- Responding to key buildings and spaces with surface material changes, enhancing impact (for example, block paved street surfaces surrounding a public open space);
- Consider carefully combining standard and alternative materials (for example, tegula paved footways with a tarmac and pressed aggregate

carriageway;

- Non-standard turning head shapes that relate to surrounding buildings and spaces whilst also meeting minimum requirements for turning vehicles (e.g. squares, rectangles, ovals and irregular shapes).

Design codes

Where appropriate, the use of design codes is recommended. Design codes can be effective in determining a detailed set of rules for a particular street and creating a range of different streetscapes throughout a development.

Developers should work in consultation with the County Highways Authority and refer to the latest version of the 6C's Design Guide⁶.

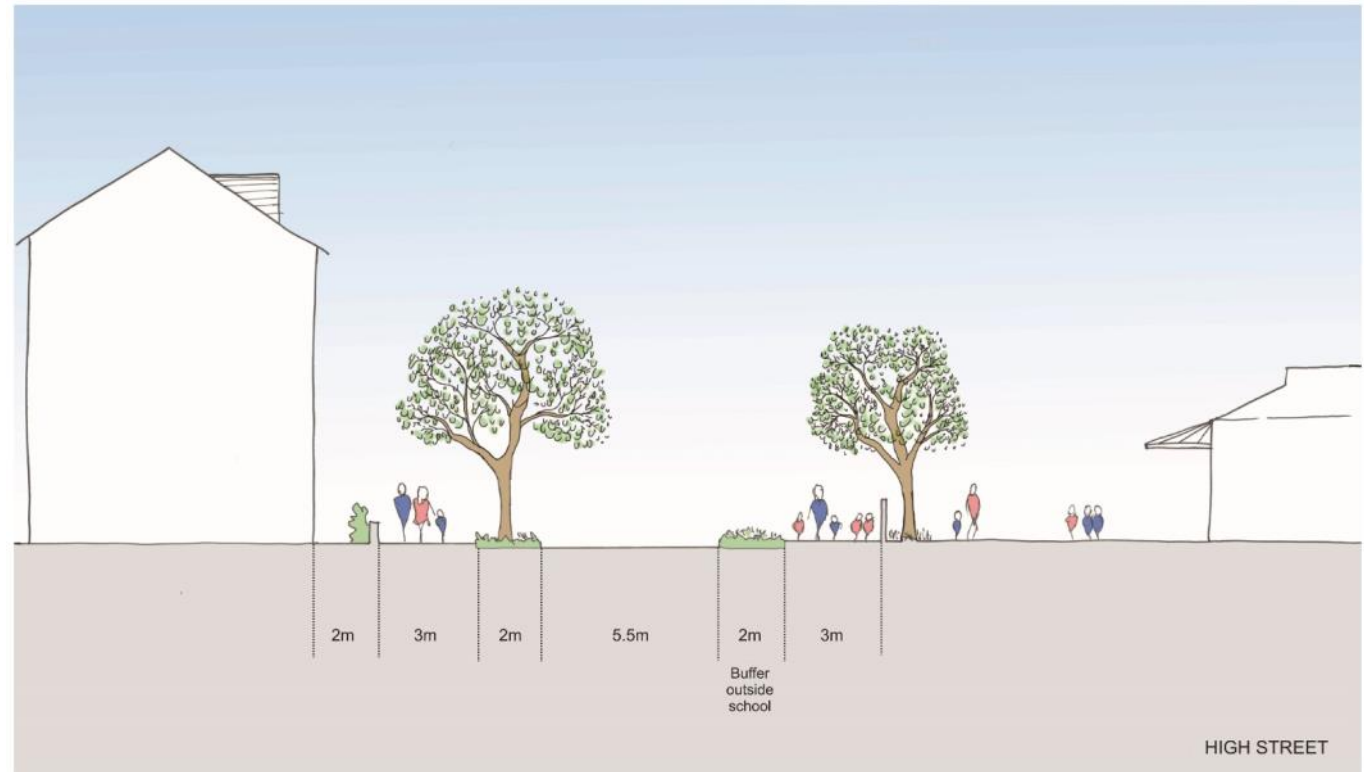

Example design code illustration for a High Street: wide pavements, buildings set forward on plots and tree lined avenue

2: DESIGN FOR WALKABILITY

The Council strongly encourages developers to ensure that streets with high place making needs are designed differently, with the needs of pedestrians being considered before those of vehicle users.

For example:

- If people are going to be encouraged to walk, the quality of the walking experience is just as important as the distance that they need to walk;
- Placing crossing points on 'desire lines' - the routes people *want* to walk, including across junctions;
- Where appropriate, tighter corner

radii to slow vehicles and reduce crossing distances, noting that long crossing distances can make pedestrians particularly vulnerable;

- On key crossing points, where possible, raising the carriageway to the pavement rather than dropping the pavement to the carriageway, in order to make crossing more comfortable for everyone in society (further guidance on raised tables in 'Design for Slow Speeds' section below);
- Level and shared surfaces³, reducing vehicle dominance and giving pedestrians more freedom, but still accounting for the needs of the visually impaired. Larger areas or 'zones' of such surfaces tend to work better than small stretches;
- Homezones – encouraging community focused streets where children are able to play. Homezones work better on quieter streets and often adopt a shared-surface approach with designated on-street parking areas, planting and street trees;

Connected pedestrian networks – ideally on streets used by vehicles, cyclists and pedestrians, rather than

on segregated, pedestrian only routes that can have poor natural surveillance. All connections should be designed to be safe and should follow the guidance in the Community Safety section. Connections should be overlooked, well lit and clear of planting that could impede natural surveillance and create potential hiding places.

- Minimise obstructions on the footway;
- No maximum width for footways – widths should take account of pedestrian volumes and composition. For example, wider pavements will be encouraged

around schools and on key routes to them;

- Inclusive streets - streets should meet the needs of all users, for example the less agile, pushchairs and wheelchairs. Routes should be direct and easy to understand (see 'Create a Navigable Place' section below);
- Where relevant, placing of key services and facilities within walking distance of people's homes;
- Co-location of community facilities as multiple reasons to visit a destination can increase the likelihood of people walking.



Example of 'level' surface street in quality materials

3: PROMOTE CYCLING

In combination, the five core design principles below contribute to a good level of service for cyclists⁷;

- **coherence** - high standards of connectivity, consistent provision, well-signed;
- **directness** - routes based on desire lines, with minimal detours or delays and offering a time-advantage over other traffic;
- **safety** - low risk of injury, good personal security; perceived as safe;
- **comfort** - minimise gradients and loss of momentum; avoid complex manoeuvres; smooth, non-slip, well-drained surfaces; minimise noise, spray, dazzle from traffic;
- **attractiveness** - aesthetically pleasing, interesting, complements surroundings.

Manual for Streets⁴ states that:

- cyclists prefer direct, barrier-free routes that avoid the need for cyclists to dismount;

- off-carriageway cycle tracks that bring cyclists into conflict with side road traffic can be more hazardous than routes that stay on the main carriageway;
- high speeds or high volumes of traffic tend to discourage cycling – traffic conditions should be addressed to make on-street cycling satisfactory;
- junctions should be designed to accommodate cyclists' needs. Over-generous corner radii that lead to high traffic speed should be avoided.

The Council strongly encourages developers to design high quality cycle routes into all developments (where relevant) and ensure that these routes connect with routes and destinations beyond the site.

4: DESIGN FOR SLOW SPEEDS

Streets with a high place-making function and low movement function (e.g. all residential and town and village centre streets) should have a 20 mph design speed⁸. Measurements for calculations such as visibility splays

and stopping distances can be amended accordingly. Streets where traffic is likely to be moving more slowly could have a design speed even lower than 20 mph.

This approach avoids overly engineered environments, creates a clearly defined hierarchy of streets and allows streets to be designed in relation to their context.

Layout design should control vehicle speeds naturally and be focused on creating characterful streets, rather than relying on unsympathetic traffic-calming measures or curvilinear street patterns that don't relate to the character vision.

Raised tables or lengths of carriageway should only be used where they relate to and enhance the character of a street or space and/or improve the environment for pedestrians and cyclists, such as where a shared cycle/pedestrian route crosses a street for example.

Lots of short stretches of raised tables should be avoided with them combined to form longer stretches or 'zones' of raised carriageway.

The impact of raised areas of carriageway on bus routes should be carefully assessed, with raised

features being kept to an absolute minimum and designed to reduce disruption to bus services. A common sense and balanced approach should be taken, with streets being designed primarily for the safety and comfort of all pedestrians and cyclists and for slow vehicle speeds, rather than for a single mode of transport such as a bus.

Changes in street surface materials on raised tables can enhance character and slow vehicles further.

Horizontal traffic calming (e.g. build-outs) should not be used unless they form a meaningful part of the street's character or benefit pedestrians and cyclists – for example street trees in build-outs with parking bays in between or build-outs on a pedestrian or cyclist crossing point.

Narrower street widths, on-street parking and tighter corner radii can help to reduce speeds (as evidenced in Manual for Streets⁴);

Reductions in forward visibility are associated with reduced driving speeds (as evidenced in Manual for Streets 1⁴ and 2⁵) and hence can be of benefit in the right places, such as mews;

Close proximity of buildings or trees to the road can help to make drivers

perceive the street to be narrower, often resulting in more cautious and slower driving behaviour.

On-street parking, shops, and pedestrian activity can also change driver perceptions and encourage slower speeds.

5: CREATE A NAVIGABLE PLACE

New developments should be easy to find your way around and it should be simple to make a mental map of the

area (be more legible).

A clear **hierarchy of streets** can help to achieve this, with streets being designed to look different to one another. A typical hierarchy includes a primary/main street, secondary streets and sometimes tertiary streets. For example:

- **Primary Street** – could include a tree-lined avenue (a formal arrangement of street trees next to the carriageway) wider pavements, strong front boundary treatments such as railings with



STREET DESIGN, MOVEMENT AND LEGIBILITY

1: CREATE HIGH QUALITY STREETS

Feature trees and landscaping within the streetscape
 Shared surfaced streets
 High quality materials

4: DESIGN FOR SLOW SPEEDS

Layout design should control vehicle speeds and focus on creating characterful streets - rather than using unsympathetic traffic calming measures
 Reduced visibility - reduced forward visibility associated with lower driving speeds

4: DESIGN FOR SLOW SPEEDS

Human activity - Increased pedestrian activity (including on-street parking) can change driver behaviour

1: CREATE HIGH QUALITY STREETS

Street design and surface materials to respond to key buildings and spaces

2: DESIGN FOR WALKABILITY

A quality walking experience will encourage more people to walk
 Wider footways where needed - such as around schools and on key routes.

2: DESIGN FOR WALKABILITY

Clearly defined areas of shared surfaced street or home zones - creating an environment where pedestrians and vehicles are more equal and share the street, encouraging lower vehicle speeds, more cautious driving and creating a more comfortable and relaxed street designed for a wider range of activities, such as children's play, street games, socialising and talking with neighbours.

4: DESIGN FOR SLOW SPEEDS

Visual narrowing - close proximity of buildings or trees make drivers perceive the street to be narrower
 Physical features - street surface material changes, raised areas/tables and meaningful / attractive build-outs

2: DESIGN FOR WALKABILITY

Comfortable crossing points for all users:

- on desire lines;
- reduced crossing distance with tighter corner radii;
- reduced vehicle speeds with tighter corner radii, surface material changes and raised table;
- level crossing surface (raised carriageway) eliminating level changes and any slightly raised kerbs that may be problematic for some people, such as wheelchair users;

3: PROMOTE CYCLING

Coherent, direct, safe, comfortable and attractive routes.
 Minimise conflict with side roads and the need to dismount.

1: CREATE HIGH QUALITY STREETS

Respond to the historic context with street surfaces and front boundary treatments
 Use quality materials on private property frontages, such as Staffordshire blue clay pavers.

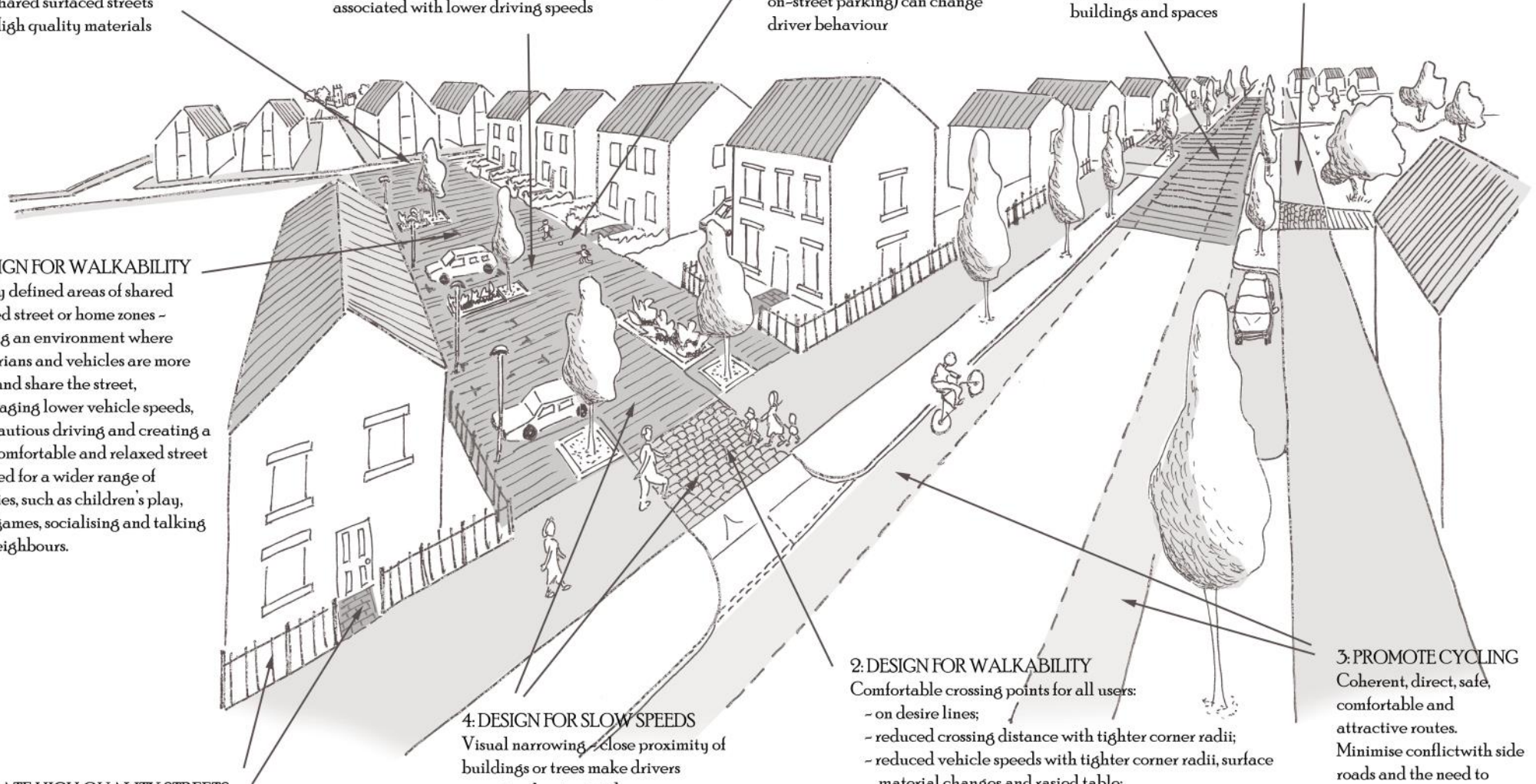

hedging behind or low walls, strong house types that have good rhythm and continuity, strong and consistent building lines or parking at the sides of properties to allow buildings to have a close relationship with the street.

- **Secondary Streets** – should still involve a strong building line, a defined front boundary such as a hedge and parking at sides of properties, but with narrower carriageway and less distance between plots across the street than with the primary street.
- **Tertiary street** – such as mews or ‘lanes’. These are shared surfaces (or 25mm kerb height) and narrower carriageway than secondary streets, and with a complete street and pavement material change (such as block or tegula paving), with the option to have grass verges abutting the highway if a rural ‘lane’ character is required.

A further tier of the hierarchy may be shared driveways or courtyards where surfacing, lack of kerbs and the addition of gateway features can indicate the less public nature of these routes whilst still ensuring their status as a route to a destination is recognised.

Connected, permeable grid layouts can help people to move more freely around developments, reduce walking and driving distances and help reduce the risk of

taking routes down streets that lead to a dead end. Cul-de-sacs should be limited in number and should

not create longer pedestrian walking routes or block desire lines to key destinations. Every effort should be made to connect developments to existing routes, whilst also considering prospective connections.



Good sightlines

Example of street hierarchy and permeable grid layout

and visibility towards destinations and intermediate points are important for wayfinding.

Landmark buildings and trees

should be instantly recognisable and memorable – giving people physical reference points from which to navigate, create mental maps from and use when giving directions to others. Town, village or neighbourhood scale landmarks work best when they have a social or cultural use, such as community buildings, schools, places of worship and retail and leisure facilities. Local landmarks can include residential properties, but must be unique and simple to describe in a few words.

Memorable/special spaces – can create breaks in the rhythm of the street and can be fundamental in helping to create a mental map of the area – for example: village greens, urban squares, water bodies and larger public open spaces. The impact of such spaces can be enhanced if the street design and materials also change to enhance the uniqueness of the space.

For developments of a size of approximately 100 dwellings or more, the creation of character areas can



help people to understand the area and create a sense of 'here and there'. Streets themselves can be character areas, but it is important to also create areas with different character, ideally relating them to the immediate context. This helps to avoid large areas of housing where everywhere feels the same.

6: CREATE CONNECTED NEIGHBOURHOODS

Connections to local services and public transport should be achievable for most people to comfortably walk

(walkable neighbourhoods). Routes should be direct, quick, safe, well lit, attractive and comfortable to use.

New developments should integrate into their surroundings by linking with and knitting in to existing connections, public rights of way, greenways, cycle routes and adjacent neighbourhoods.

Connections and strong routes through developments should be designed into schemes early on and should serve as fixed features for layouts to mould themselves around.

New development should not

compromise future connections to adjacent land. The Council strongly recommends that opportunities to provide connections are included within development proposals (unless the applicant can demonstrate that this is due to circumstances beyond their control).

In order to enhance connectivity, reduce walking distances and create areas that are easier to navigate and understand, the Council will discourage the use of dead-ends or cul-de-sacs. If there is a need to restrict vehicle access, pedestrian and cycle access should be retained.

Not all connections will need to be accessible by vehicles and it is likely that more connections can be made if some are pedestrian and cycle only, creating a more connected neighbourhood.

All connections should be designed to be safe and should follow the guidance in the Community Safety section. Connections should be overlooked, well lit and clear of planting that could impede natural surveillance and create potential hiding places.

7: DELIVER VIABLE PUBLIC TRANSPORT ROUTES

The opportunity for public transport routes within the site should be considered at the start of the design and masterplanning process, with optimum routes being planned in order to create bus service routes that are fast, direct and collect the maximum number of passengers to ensure that services are well used and viable. Linear routes are preferable and overly circuitous routes should be avoided.

Proposals for new development should aim to ensure that public transport services are within walking distance of people's homes (within 500m is desirable).



Buttercup Leys, Boulton Moor: strong tree-lined pedestrian and cycle connection to adjacent neighbourhood

8: MAKE PARKING COMFORTABLE

Insufficient and poorly designed parking can have negative impacts on how streets function, can create cluttered and chaotic environments and can create unnecessary neighbour and community conflicts and divisions.

The Council recommends that:

- The required number of parking spaces is provided on-plot and located behind the building line, between dwellings and/or on drive through units/car ports. This is to enhance street character and maintain strong building lines and front boundary treatment lines, and avoid parked cars dominating the street;
- Dwellings with on-plot parking in front of the building line should be avoided. Where necessary they should be limited in number and located sensitively within a development. This parking should be located away from Primary/Main streets or streets where it does not fit with the desired character. Such parking should be softened with landscaping, ensuring landscaped space equals or exceeds that of hardstanding (also see integral garages section below);

- Off-plot frontage parking for linked units/terraces should be softened and broken up with street trees. Adequate space should be provided to ensure that trees do not block paths or hinder movement around spaces. A consistent building line should be maintained.
- Streets should be designed to accommodate unallocated on-street parking for visitors and overflow. This could take the form of parallel or herringbone bays. If on the adopted highway, this should be designed in consultation with the Highway Authority.
- Residents should be able to see their car from within their homes. Secondary windows to habitable rooms and to hallways should be provided for parking at the sides of dwellings.

Amount of residential parking spaces

The Council strongly encourages developers to provide at least two spaces per dwelling. For homes of four bedrooms or more, it is recommended that three spaces are provided.

For flats, it is recommended that one unallocated visitor space is provided for every two dwellings (half a space per dwelling).

These spaces should ideally be in addition to any garage provision. See the size section below to find out what constitutes a parking space within a garage.

Variations may be considered due to location (such as town centre sites).

Please see the latest version of the 6C's Design Guide⁶ for further guidance on parking provision, particularly in respect of non-domestic properties.

Size of parking spaces

Driveways and parking spaces on residential developments should be wide enough to allow the doors on both sides of the car to be opened sufficiently, in order to provide comfort of use for all users. This includes, for example, the mobility impaired, older people, people with young children and people unloading luggage and bulky items; all of whom require the door to be opened wide in order to get in and out of the car. If a driveway is to be fit for purpose and serve a dwelling and its wide range of residents and their needs over time; it is recommended that the guidance below is followed:

Residential car parking space size rules:

- Absolute minimum of 2.4m (width) by 5.5m (length);
- Designers should ideally add 0.5m width if bounded by a wall, fence, hedge, line of trees or other obstructions on one side, and add 1m if bounded on both sides. All other parking spaces (not bounded on either side) should include additional hardstanding/paths to allow room for people to manoeuvre around their car and to carry bins past vehicles (at least 0.6m per space);
- Parking for plots that have a shared driveway (excluding frontage parking areas for terraces) should ideally be separated by a 1m landscape strip with hedgerow, ensuring that there is room to manoeuvre around vehicles.
- Tandem, triple width parking bays (i.e. 6 parking spaces) in one location will not be permitted unless each tandem space is separated by a 1m landscape strip with hedgerow.

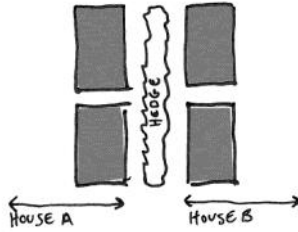

Parking separated by landscape strip with hedge

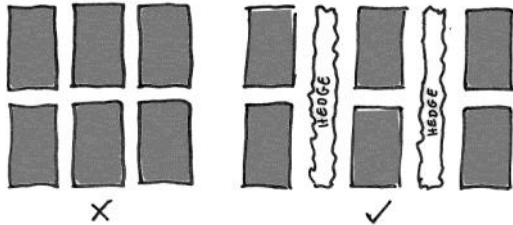

Garages size rules and design guidance

If a garage is to be fit for purpose, it is recommended that a car should be able to be driven inside comfortably and there should be space within the garage to get out of the car on both sides. The storage of items within the garage also needs to be considered.

If a garage is to be counted as a parking space, it is recommended that the following three criteria below are met (please also refer to the latest version of the 6C’s Design Guide⁶). Failure to meet these criteria could

Type of Garage	Internal Dimensions for Garages (Width x Length)		Garage Door (Width)
	Preferred	Absolute Minimum	Absolute Minimum
Standard single	3.6m x 6.5m	3.0m x 6.0m	2.3m
Use by disabled people	4.2m x 6.5m	3.3m x 6.0m	2.8m
Double	7.2m x 6.5m	6.0m x 6.0m	4.2m

result in the garage not being counted as a parking space.

- Garages should meet the minimum requirements set out in the table above;
- In addition to the minimum requirements in the table above, suitable storage provision for items that are usually stored within a garage should be provided (e.g. for bicycles, DIY and garden maintenance equipment). This could be achieved by providing a larger

garage (following the preferred garage dimensions in the table above) or providing a suitable storage building such as an outhouse.

- Garages should be well positioned to ensure that they do not dominate the street scene in a negative way.

Integral garages can produce visually unsatisfactory principal elevations in certain contexts and need to be sensitively designed and located. It is recommended that the guidance below is followed:

- Integral garage house types should be used sparingly and not located on primary routes, in prominent places or where they may erode the intended character of the street or space;
- Attention should be drawn away from the garage element of the building by ensuring that it is set back behind the habitable part of the home. Dominant architectural features such as large gables can also help create a positive focal point;
- Front gardens and landscaping can help to soften the visual impact of garage doors and parked cars.

Rear parking courtyards and car parks for flats

Rear parking courts should be a last resort and should only be used once other options have been exhausted or if there are clear place making benefits (for example, to create strong frontages overlooking a key space). Poorly designed parking courtyards are often not used by residents and lead to surrounding streets and pavements becoming cluttered with cars. Parking courtyards and car parks for flats should be safe, comfortable and pleasant to use.

It is recommended that the guidance below is followed:

Rear parking courtyards

- Rear parking courtyards will be discouraged;
- Occasional parking courtyards will be permitted, if justified and if they are designed to a high standard and treated as part of the public realm, as set out below;
- They should be kept small (ideally maximum of 5 properties);
- There should be properties

located at the entrance and also within the courtyard itself, with habitable rooms at ground floor overlooking the access and parking areas;

- Block paving should ideally be used to delineate bays and modest markings should be used to label them.
- Boundary walls, not fences, should be used and set back from areas where vehicles and pedestrians will move, so to offer the opportunity for landscaping and relief from an otherwise enclosed environment.

Rear parking courtyards and car parks for flats

- These should be well overlooked, avoiding any hidden corners or parking spaces and with habitable rooms at ground floor fronting the parking area;
- Boundaries facing the parking area and entrance(s) should be brick walls with detailing (e.g. coping stone, tile crease and detail courses);
- They should be well-lit and

include some element of low-level lighting, such as bollard lighting;

- Parking areas should include robust and suitable landscaping in order to soften the space;
- The distance from the parking space to the front door of the associated house should be short and direct. Access to the rear of properties is less favourable and must lead directly in to the kitchen, hallway or utility room.

Cycle parking

Safe, secure and convenient cycle parking should ideally be provided for all development sites. For housing schemes, cycle parking could be accommodated in garages and where garages do not exist; alternative options should be provided where practicable. For flats, communal cycle parking should be provided either outside (covered, well lit, secure, overlooked) or ideally designed into the interior of the building.

Please also refer to the latest version of the 6C's Design Guide⁶.

Further resources

Car parking, what works where
(English Partnerships, 2006)

Streets for All, East Midlands, English
Heritage and DfT, (2005),

www.spacetopark.org/

STREET DESIGN, MOVEMENT AND LEGIBILITY 2

5: CREATE A NAVIGABLE PLACE

Good sightlines and visibility towards destinations
Connected, permeable networks of streets

5: CREATE A NAVIGABLE PLACE

Character areas can help people understand larger developments and create a sense of 'here' and 'there' - avoiding the problem of everywhere feeling the same.

8: MAKE PARKING COMFORTABLE

Ideally on-plot and behind the building line at the sides of properties
Off plot frontage parking should be softened with street trees
Residents should be able to see their car from within their homes

5: CREATE A NAVIGABLE PLACE

Landmark buildings and trees
Memorable / special places

6: CREATE CONNECTED NEIGHBOURHOODS

Strong connections with surrounding settlements, footpaths and cycle routes

5: CREATE A NAVIGABLE PLACE

Clear hierarchy of streets - primary, secondary and tertiary - designed to be distinctly different

7: DELIVER VIABLE PUBLIC TRANSPORT ROUTES

Masterplan strategically to create viable public transport routes - Fast, direct, ideally linear and collect maximum number of passengers

8: MAKE PARKING COMFORTABLE

Streets designed to accommodate unallocated on-street parking for visitors and overflow

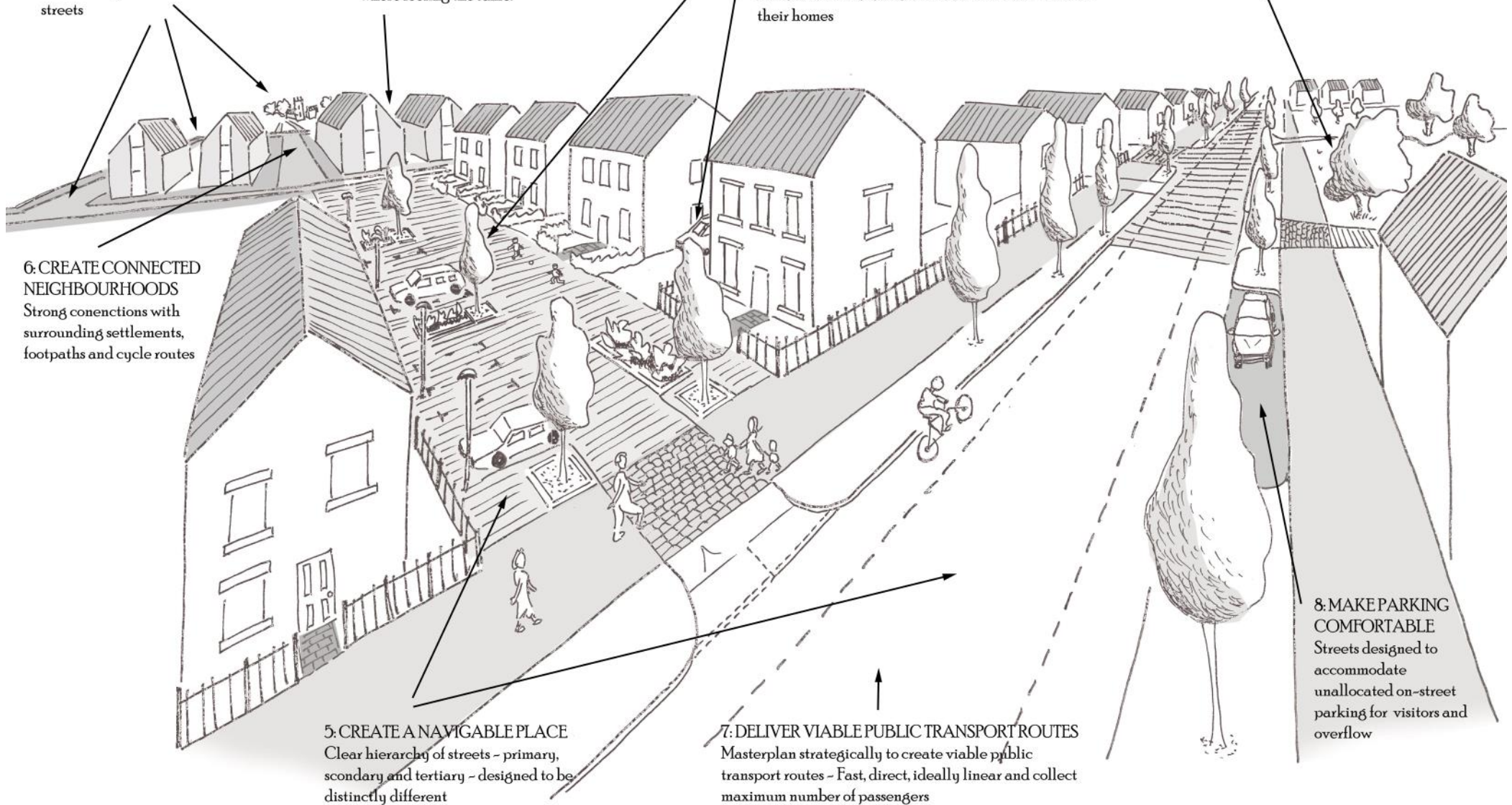

Diversity and community cohesion

BNE1 c) Diversity and Community Cohesion

New development should be designed to be diverse, vibrant, possess a sense of place and encourage social interaction.

Background

The aim is to create more opportunities for people to meet and for communities to develop and strengthen.

Creating a mix of uses, within a building, street or an area or neighbourhood, can have multiple benefits. A mix of uses can:

- Create safe town, village, district and suburban centres that are

vibrant and have people coming and going at different times of the day;

- Create walkable neighbourhoods and healthy lifestyles, allowing people to walk to services and facilities such as the local shop, bus stops, schools and public open spaces;
- Decrease reliance on the private car, reducing air pollution and creating more inclusive neighbourhoods that do not exclude people without a car, or who are unable to drive;
- Address the needs of a growing ageing population, helping people live independent lives for longer by having amenities, services and opportunities for social interaction and community involvement close to where they live;

- If concentrated together and designed with quality public space, help to increase opportunities for social interaction and create lively areas with a sense of place.

Key Actions

1: ENCOURAGE A SENSE OF BELONGING AND COMMUNITY TOGETHERNESS

Character areas add diversity to large residential developments, creating a sense of being 'here' or 'there'. Street characters should differ dramatically, but whole areas of large developments should feel different from one another, responding to their varying contexts or creating new character areas, zones or quarters. This can help people to feel that they belong somewhere – to a street or to a defined neighbourhood.

Mixed tenures and affordable housing types – it is important to make sure that these are not distinguishable from other types of housing and also not positioned in the least attractive areas or grouped together too much; maximum of 10 dwellings in one group, including back to back properties. Please also refer to the District Council's Affordable Housing Supplementary Planning Document.

Sense of place – Development should be designed to possess a sense of place. This is largely made up of two factors – form and function. Somewhere with a sense of place possesses some or all of the factors below:

- is connected to the local character of the area in some way or possesses a new unique character of its own;
- has a feeling of being well enclosed by buildings or landscape, making people feel comfortable, safe and relaxed;
- can be related to, at a human scale, with detailing and richness at eye level;
- possesses a sense that something is going on there – with people coming and going at different times of the day and a certain degree of 'buzz' and vibrancy;
- lifts the spirits – visually with high quality buildings, street surfacing or landscaping and/or because of the atmosphere created by people, sounds, scents.



Millbrook, Station Road, Melbourne: strong sense of place

2: CREATE DIVERSE PLACES WHERE PEOPLE CAN MEET

All residential development should be designed to maximise opportunities to create vibrant mixed-use environments. Residential areas should have a range of services and facilities within walking distance.

Town, village and local centres should have a mix of uses (for example, residential units above commercial units will be encouraged). Mixed-use developments and areas with both daytime and evening uses will be encouraged.

The mix of uses should be compatible with one another and interact positively. Development should be designed to increase opportunities for people to interact with one another.

This can have a big impact on people's quality of life and can also create stronger, safer and more inclusive communities.

New development should aim to

include:

- a concentrated mix of uses with good quality public realm (providing greater opportunities for people to interact, for paths to cross and serve as meeting places);
- an element of on-street parking (to help create a more vibrant street and increase the chances of seeing and meeting other people);
- quality landscaped front and side gardens (even if small, these can encourage more time to be spent at the public frontage of the house, increasing activity on the street and opportunities to see and meet others);
- streets designed with children's play in mind (such as homezones and shared surface streets);
- wider pavements (increase the likelihood of people stopping and talking to one another and can

also accommodate outdoor seating for cafés or on-street shop displays);

- new communities that include allotments and community centres;
- community notice boards located where people are likely to stop and read them;
- public open spaces that are designed for a range of different people (children of all ages and older people for example) help bring people and communities together;
- initiatives to encourage social interaction through the internet (developer, council, community or business led);
- community consultation as part of the design process – to get existing residents involved in new development with the aim of encouraging them to see the new development as part of their

neighbourhood and avoid the 'them' and 'us' mentality.

3: INTEGRATE LOCAL CENTRES INTO THE TOWNSCAPE

In addition to the advice above, local centres on new residential developments should possess a sense of place and be seen as the heart of the local community and should:

- not be designed as segregated retail and leisure areas, but be knitted and intertwined into the residential layout, with parades of units fronting the street or public squares framed by units for example;
- include residential elements (including care homes), for example at first floor level or adjacent to and integrated with units;
- ensure a diverse range of units, such as shops, cafés and

community buildings;

- incorporate quality public space and landscaping that form clear neighbourhood centres and encourage people to stay longer;
- have community buildings, schools and public open spaces nearby to enhance the levels of activity, vibrancy, social interaction and safety with people around at different times of the day;
- include bus stops nearby to encourage public transport use and to increase linked trips and footfall next to the local centre, as well as adding to vibrancy, social interaction and safety.

4: DESIGN STREETS AND PUBLIC OPEN SPACES FOR THE WHOLE COMMUNITY

Public open spaces should be

designed to ensure that they can be used by a range of different people and for a range of activities. They can also be located close to other community facilities and services to create community focused and connected areas as described above.

This could include:

- play equipment and facilities for a wide range of age groups (for example: trim trails suitable for older children and adults, hard-surfaced football and basketball areas, skate-parks and more challenging play equipment for the over 10's);
- A choice of pleasant places to sit and relax, particularly for the older generation (but not necessarily all separate from places for children and young people);

Please refer to the District Council's Open Space, Sport and Community Facility Strategy 2016⁹ for further guidance on open space design.

DIVERSITY AND COMMUNITY COHESION

2: CREATE DIVERSE PLACES WHERE PEOPLE CAN MEET

- on-street parking;
- quality landscaped front and side gardens;
- streets designed for childrens play (homezones and shared surfaces);

1: ENCOURAGE A SENSE OF BELONGING AND COMMUNITY TOGETHERNESS

Sense of place - character, sense of enclosure, human scale (detail and richness at eye level), sense of something going on and vibrancy, lifts the spirits

4: DESIGN STREETS AND PUBLIC OPEN SPACES FOR THE WHOLE COMMUNITY

Streets and public open spaces designed for a wide range of people
A choice of pleasant places for a wide range of people to spend time and relax in

1: ENCOURAGE A SENSE OF BELONGING AND COMMUNITY TOGETHERNESS

Mixed tenures and housing types - integrated in to developments

3: INTEGRATE LOCAL CENTRES IN TO THE TOWNSCAPE

Knitted and intertwined in to the residential layout
Consider residential at first floor level
Diverse range of uses - shops, cafes, residential
Quality public realm and landscaping
Co-locate local centres with other facilities such as schools, public open spaces, community buildings and public transport

2: CREATE DIVERSE PLACES WHERE PEOPLE CAN MEET

Create mixed-use developments
Design environments that increase opportunities for social interaction

- concentrated mix of co-located uses with quality public realm;
- wider pavements - increased likelihood of people stopping and talking;
- Community notice boards.

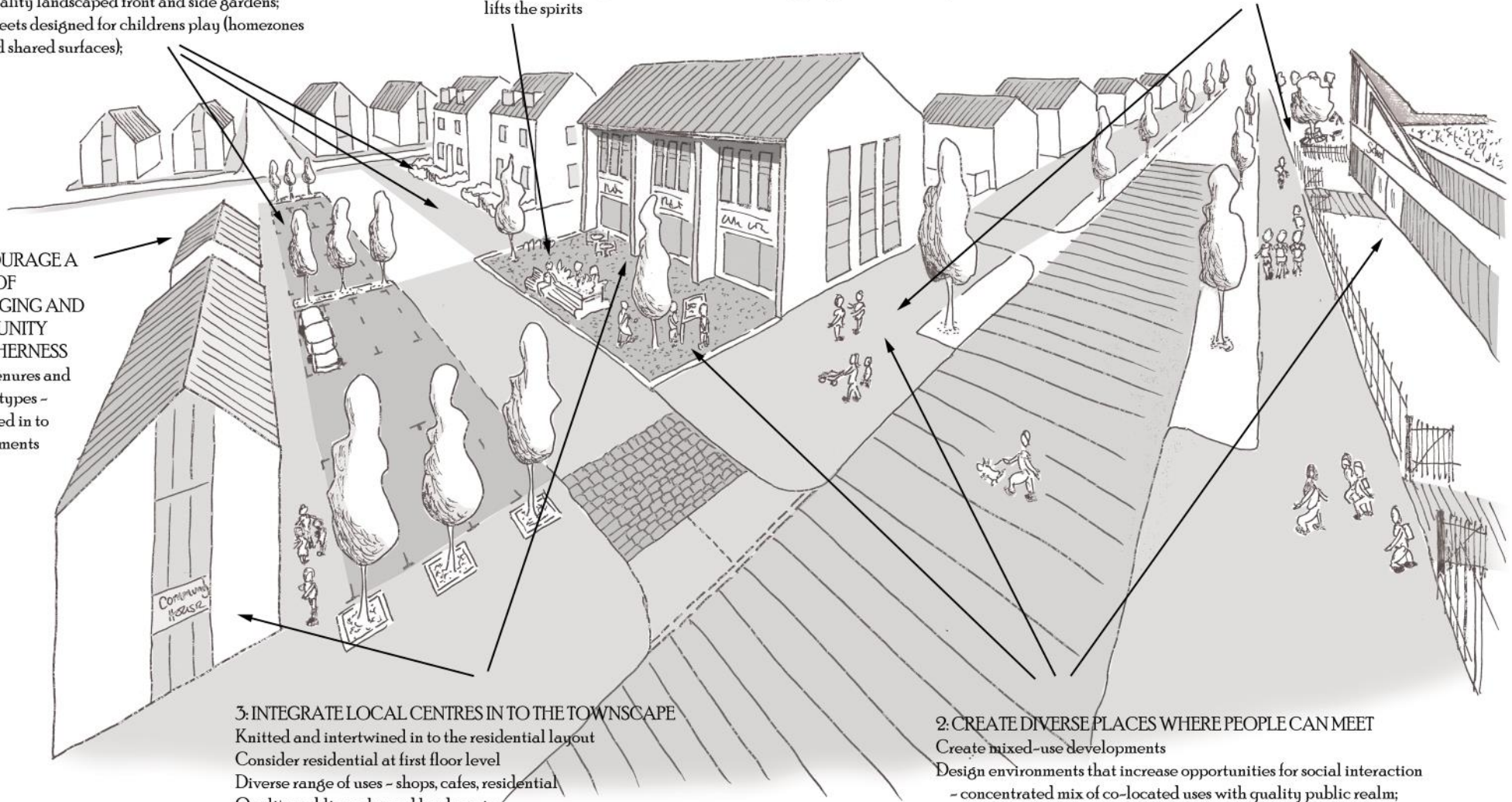

Ease of use

BNE1 d) Ease of use

New development should be accessible to all user groups, well managed and should be able to adapt to changing social, environmental, technological and economic conditions, including the needs of an ageing society;

Background

There are three core elements to what constitutes good design and two of these relate directly to this chapter - Firmness (will it last) and Functionality (does it work). Good design is often approached, defined and understood too narrowly, with focus solely being on how things look. But how places function and whether they are simple and easy to use and making sure that they are designed to withstand the tests of time and being low maintenance is very important.

Key Actions

1: DESIGN PLACES THAT CAN BE USED BY ALL

The concept of universal design should ideally be applied to all development – ensuring that the default standard design solution is one that can be used comfortably by people of all ages and abilities. (For example, low floor buses are now the standard design and are accessible to all).

Some specific examples include:

- Parking areas should be fit for purpose - see section 8 of the Street Design, Movement and Legibility Chapter;
- Streets should be designed for all in society and careful thought should be given to the location of dropped kerbs, ensuring that they are on desire lines and places where people need to cross. On

the most frequently used routes, the carriageway should ideally be raised to the level of the pavement (raised crossing or table), creating crossing points that don't involve gradients that can prove to be less comfortable for wheelchair users and less able-bodied people for example;

- New neighbourhoods should be designed to be 'walkable' and also easy to navigate around, so that they are accessible to everyone in society. This allows people without a car or who are unable to drive, to easily access bus services, shops and community facilities. People less confident about making trips out, can also feel more confident if they can follow direct, clear routes.

2: DESIGN BUILDINGS THAT CAN BE USED BY ALL

Just as outdoor places should adopt the principles of universal design, buildings themselves should also do so and be fit for purpose.

The main entrance to a building should be accessible to all, with flush, level surfaces and sufficiently wide doorways. Entrances that exclude certain members of society and provide separate access points elsewhere in the building create social divisions and alienate people and should be avoided.

The Council will expect applicants to demonstrate that homes have been suitably designed for the maximum number of occupants and the expected amount of furniture. It is recommended that furnished internal floor plans are submitted as part of the planning application and these plans should demonstrate that:

- A particular room is able to fulfil

its intended purpose (for example a single bedroom would be expected to include a single bed, a bedside table, a wardrobe and space to dress and move around items of furniture);

- The living room can accommodate the maximum number of occupants;
- The maximum number of occupants can sit around a table together;
- A space to allow work at a desk to be undertaken (away from the kitchen or living room – could be on a landing, in a bedroom or dining room);
- Sufficient internal storage space (for example for a vacuum cleaner, shoes, coats and pushchairs);

Quality of life can also be affected by the internal environment of a building and the amount of natural light. Buildings should be designed and orientated to ensure that good levels of natural light are achieved – for example, habitable rooms with no windows or single aspect north facing flats will be discouraged.

3: CONSIDER DEMOGRAPHICS

National demographic trends along with any specific demographics of an area should be considered. Places should be designed to consider the needs of different demographic groups.

The proportion of older people in society is rapidly increasing and the needs of this ageing society must be comprehensively catered for. Such needs are wide ranging and older people should not be classed as a single group, due to the differing needs and capabilities of each individual.

However, the following broad measures should ideally be taken:

- The design of new homes should take account of the Lifetime Homes standards¹⁰ and meet as many of the criteria as possible (see Appendix D for details of the 16 Lifetime Homes criteria);

- Public spaces and footpaths should include seating options designed with older people in mind;
- Streets and spaces should adopt the principles of universal design (as described above);
- Independent lifestyles should be facilitated through design, allowing people to 'age in place' (adaptable housing), have access to shops, bus services and community facilities (walkable neighbourhoods) with comfort and ease (universal design) and without the fear of crime and anti-social behaviour (section on community safety);
- Opportunities for social interaction should be provided, promoting a sense of identity as a full member of society (see also Diversity and Community Cohesion section);
- Healthy, active lifestyles

should be encouraged through design (see healthy lifestyles section).

4: BE PREPARED FOR CHANGE

Development should be able to adapt to changing social, environmental, technological and economic conditions. The most successful places have survived and adapted to changing circumstances. New development could include:

- Corner buildings on main streets that have adaptable ground floors that can accommodate different uses over time (e.g. ground floor conversion to small retail unit);
- Public spaces should be able to adapt and cater for different uses, such as events, festivals and markets;



- Public green spaces should be able to accommodate the above in addition to providing some options for different sports, such as rounders, football and athletics;
- Roof spaces within buildings can be made more suitable for conversion if pitches are steeper, giving greater floor to ceiling heights;
- Larger plot sizes and adequate space at the sides of properties can help accommodate extensions. Larger rear gardens can help broaden options for rear extensions;
- Homes and buildings that can be easily extended or altered internally can accommodate a wider range of uses and changes in use over time;
- Electric Vehicle recharging infrastructure within the development (wall mounted or free standing in-garage or off-street points);

- Provision of adequate space for waste storage to allow for potential changes in kerbside collection such as the collection of additional waste streams and/or changes to the frequency of the general waste service.
- Developers are encouraged to install sprinkler systems in to new properties. Alternatively, measures should be taken to assist with future installation.

5: MAKE BIN STORAGE AND COLLECTION SIMPLE

Recycling is a key element of sustainable development. Requirements can change over time and storage areas should be easy to use and able to adapt to change. The following guidance should be followed:

Houses

Contact the Waste and Recycling Department for the latest information.

Dedicated storage areas should be provided so that bins are out of sight of public view. If storage areas are in rear gardens, these should be screened from view.

Where bin storage is not possible in the curtilage

The following capacities need to be accommodated where bin storage is outside of the curtilage:

240 litres general refuse per apartment (can be added up and 1100 litre bins used);

240 litres recycling per apartment (1x 240 litre bin per dwelling)

If flats have gardens, then- 1x240 litre brown bin per apartment.

The Council will not accept communal bins for recycling or garden waste.

Contact the Waste and Recycling Department for the latest information.

A bin storage area should be provided and the design should ensure that there is sufficient space for people to access the bins to put waste in and also space for refuse collectors to get them out on collection days (bin dimensions provided below).

Bin storage areas should be secure and designed to complement the style and character of adjacent buildings. The location of bin storage areas should be carefully considered so as not to appear unsightly in the street scene, whilst also being located practically for collection day.

Private drives (not designed for a refuse vehicle to turn in)

Bin collection areas should be provided for private drives. These should be clearly demarcated with hardstanding that could be of a different surface material. The hardstanding should be large enough for the appropriate number of bins (on some days, two bins per household are collected).

Contact the Waste and Recycling Department for the latest information.

A metal plate fixed to the ground or adjacent wall should state 'Bin and recycling collection point, please remove bins on the same day as collection'.

Planning for bins from the outset of the design process

For all types of housing arrangements, there should be a clear route from the storage area to the street. This should be wide enough (at least 0.6m for a standard bin), not include any steps, not be obstructed by parked vehicles and should not involve carrying bins through the home, car port or garage.

6: CREATE PLACES THAT ARE EASY TO MANAGE

Development should be designed so that it is easy to maintain and manage, whilst also balancing this with the need for quality, characterful streets and spaces.

Public and private spaces should be clearly defined. Owners of private spaces, such as front and side gardens and landscaping should be clear in their

maintenance roles and responsibilities. Strong boundary treatments, such as low hedges, walls and railings, can help to avoid ambiguous and neglected areas of grass for example.

Public space should be clearly defined and easy to maintain. It should be clear that such areas are for public use, giving these areas a clear function, with footpaths and seating can clarify their public status.

Very small grassed public areas, such as narrow strips adjacent to the carriageway under 2m² should be avoided as they are difficult to maintain and often get walked over or parked on and the grass worn away.

If non-standard materials are used on private drives, such as permeable paving or special surfaces over root protection areas, owners need to be made aware of the purpose for these surfaces and how to maintain them.

EASE OF USE

3: CONSIDER DEMOGRAPHICS

Consider the needs of an ageing society and older people's quality of life - facilitate independent lifestyles:

- adaptable housing;
- key services and facilities within walking distance;
- safe and comfortable streets;
- opportunities for social interaction and active lifestyles

2: DESIGN BUILDINGS THAT CAN BE USED BY ALL

Include furnished internal floor plans with planning applications

Demonstrate that a particular room can fulfill it's intended purpose

- a double bedroom with space for a standard double bed, two bedside tables, a wardrobe and space to dress and move around items of furniture;
- maximum number of occupants can sit around a table together

4: BE PREPARED FOR CHANGE

Help accommodate extensions with larger plot sizes, including larger rear gardens

Minimise the number of load-bearing internal walls to allow internal spaces to be more easily altered

Make provision for potential future electric car charging points

6: CREATE PLACES THAT ARE EASY TO MANAGE

Clearly defined public and private spaces
Strong boundary treatments

5: MAKE BIN STORAGE AND COLLECTION SIMPLE

Design for bins from the outset
Clear route without steps from the storage area to the street, avoiding going through homes, garages or car ports.
Allow space (at least 0.6 metres) to get past any parked vehicles.

4: BE PREPARED FOR CHANGE

Corner buildings on main streets that have adaptable ground floors
Roof spaces within buildings made more suitable for conversion with steeper pitches

4: BE PREPARED FOR CHANGE

Public spaces should be able to adapt to cater for different uses, such as events, festivals and markets

2: DESIGN BUILDINGS THAT CAN BE USED BY ALL

Main entrance accessible to all - ideally flush surface with sufficiently wide doorways.

1: DESIGN PLACES THAT CAN BE USED BY ALL

Streets designed for all - including crossings that are comfortable for all (level surfaces for wheelchair users and less able bodied people for example).
Walkable neighbourhoods - easy to navigate around and key services and facilities within walking distance of people's homes

1: DESIGN PLACES THAT CAN BE USED BY ALL

Universal design - comfortably used by all - parking areas should be fit for purpose
3: CONSIDER DEMOGRAPHICS
Lifetime Homes standards require parking areas to be as convenient as possible for a wide range of people (including people with reduced mobility and/or those with children)

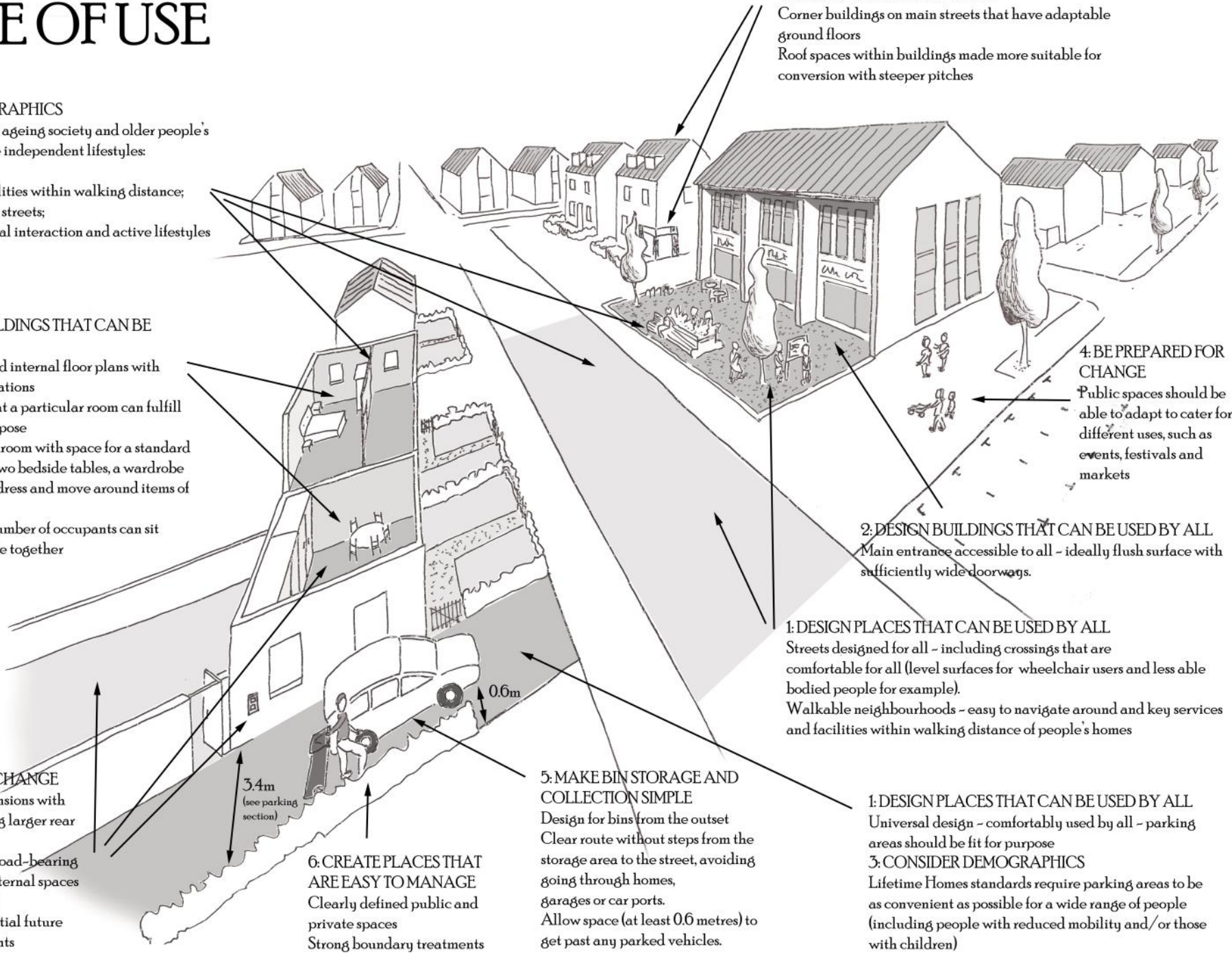

Local character and pride

and Visual Attractiveness

BNE1 e) Local Character and Pride

New development should create places with a locally inspired character that respond to their context and have regard to valued landscape, townscape and heritage characteristics.

BNE1 g) Visual Attractiveness

New development should be visually attractive, appropriate, respect important landscape, townscape and historic views and vistas, contribute to achieving continuity and enclosure within the street scene and possess a high standard of architectural and landscaping quality.

Background

The UK has a wide range of architectural styles and materials – you will see stone walls and buildings in the Peak District, warm yellow sandstone in the Cotswolds, flint cobble clad buildings in North Norfolk and buff bricks in Cambridgeshire. These vernacular materials have been found locally and relate to the geological map of the country and different colours of clay. South Derbyshire has red bricks, plain clay tiles and occasional stone walls and stone elements of buildings.

Nationally generic building types rolled out around the country over the past half a century have eroded local and regional identity in many instances.

One of the key aims of this guidance is to ensure that South Derbyshire retains its identity and plays its part in enhancing the special character of the

National Forest and the geological region to which it belongs, helping to preserve and celebrate national variety.

Where appropriate, all new development should be required to demonstrate how it relates to the local context and what contribution it has made to local distinctiveness and identity. Development should also achieve a high standard of design quality. Innovative and contemporary design solutions that reference local character will also be encouraged.

Typical South Derbyshire Characteristics

A more complete guide is contained within Historic South Derbyshire in Appendix G, but some typical South Derbyshire characteristics are listed below.

These special characteristics, once identified, should be used to inspire and inform the proposed development to ensure that it fits into and references the local area and does not degrade or attempt to apply insensitive nationally generic solutions.

- Red clay brick (often including other hints of colour such as dark grey, blue, purple, brown and yellow – i.e. ‘multi’ bricks);
- Plain clay tiles – most commonly blue, occasional red (traditionally with a minimum roof pitch of 40 degrees) with thin leading edge and traditionally proportioned;
- Slate tiles – common in Victorian and Edwardian areas and next to canals and railway lines;
- Stone: evident but never to the exclusion of brick – forming lower courses or complete sides of dwellings or in boundary walls;
- Render – some examples, predominantly stucco (smooth lime based mix);
- Staffordshire Blue bricks (largely in Victorian and Edwardian contexts);
- Glazed tiles (traditionally on Victorian and Edwardian shop fronts but also used in contemporary schemes when appropriate) (see Historic South Derbyshire in Appendix E for more information on shop front design).

Key Actions

1: START OFF ON THE RIGHT FOOT

The Council strongly encourages developers to follow the Design Process set out at the start of this document.

The development site should be visited and a detailed and comprehensive site and context appraisal should be undertaken. Joint site visits with the development team and the District Council can be very effective in establishing a deeper understanding of the context and coming to an agreement about local character.

The aspects of local character below along with the checklist in Appendix B provide information about the factors that need to be considered when undertaking a site and contextual appraisal.

2: CONSIDER ALL ASPECTS OF LOCAL CHARACTER

This section includes the following:

- **Landscape and topography**
- **History**
- **Views and vistas**
- **Streets and spaces**
- **Urban structure and urban grain**
- **Architectural style and detailing**

Aspects of local character that need to be assessed and used to inform the proposed design are detailed below along with best practice design guidance and the various elements that help to define visual attractiveness.

Landscape and topography

Landscape character areas

Development sites that are set within a landscape context should take account of the character of the surrounding

landscape. Appendix E illustrates the different landscape character areas within Derbyshire. South Derbyshire has a number of different landscape character areas, including coalfields, claylands, Trent Valley washlands, Melbourne Parklands and the Mease/Sence Lowlands. These broad tracts of countryside display special characteristics.

The Council strongly encourages new development to be designed to respect and knit in to these landscape character areas – helping to protect and enhance these valued, locally distinctive landscapes and wildlife habitats.

More detailed information and guidance can be found in the Landscape Character of Derbyshire¹¹ document (fourth edition, March 2014) - In particular this document includes information on locally used materials, as well as woodland and hedgerow species mix: <http://www.derbyshire.gov.uk/environment/conservation/landscapecharacter/>

The character vision for the National Forest should also be taken into account – please refer to the National Forest section of this Design SPD.

habitat creation.

owls.

Local landscape character

In addition to the wider landscape character issues above, local landscape characteristics and wildlife habitats should also be taken account of. This could include factors such as hedgerow alignments and species, mature tree locations, groupings and species, watercourse routes and characteristics and wildlife habitats such as meadows, woodlands, wetlands and reedbeds.

New development should aim to preserve and enhance local landscape characteristics and wildlife habitats in order to keep the special character of the area alive and ensure that proposals successfully knit in to their surroundings.

Simply retaining existing landscape elements such as trees, hedgerows and watercourses within development sites will not be sufficient – developers will be expected to design schemes around these landscape assets and make features out of them (if appropriate). This will often require additional complementary landscaping and wildlife

Where local landscape character is weakly defined, developers will be expected to create new areas of landscaping and wildlife habitats, being considerate of the wider landscape character areas whilst also being innovative and creating high quality landscaping schemes with clearly defined characters and wildlife habitats.

The Council expects a high standard of landscaping quality within new developments.

Wildlife habitats

The Council will strongly encourage developers to create wildlife habitats and to think about specific species and the environments within which they will flourish.

This should include works in appropriate locations to protect and enhance target species such as: adder, all bat species, lesser spotted woodpecker, barn owl, ruddy darter dragonfly, bluebell, black poplar, otter and water vole. Simple examples include permanently wet ponds for dragonflies and nest boxes for barn

Sustainable Drainage Systems (SuDS)

Sustainable Drainage Systems (SuDS) are of great habitat value and can help to create an attractive and characterful landscape, as well as forming greenways through developments, when suitably designed. For example, over ground water courses and swales designed into a scheme and permanently wet drainage ponds with native wetland planting can have a big impact on the visual attractiveness and character of a development. SuDS also form points of interest on footpath routes through green infrastructure.

The Council will expect developers to design SuDS into all schemes (as appropriate to the site and ground conditions). This should be done early on in the design process so that SuDS can be successfully integrated into both the ‘hard’ and ‘soft’ parts of the layout.

Characterised by buildings or landscape?

Some developments and/or streets and spaces within developments may be predominantly characterised by buildings, some may be characterised

by landscape. In order to create a strongly defined character, it can be helpful to simply aim for one or the other – characterised by landscape or characterised by buildings. A street characterised by buildings would have well designed, characterful buildings set forward, enclosing the space and allowing a close relationship to be had with them. A street characterised by landscape would have an abundance of high quality landscaping with a strongly defined character –the landscape dominating the street scene more than the buildings.

Topography

The topography of the land forms the character of the wider landscape and new developments should work with this rather than against it. Thought should be given to roofscapes and drops in levels should be addressed sensitively and creatively, avoiding the excessive use of dominant retaining walls.

History

The study of historic maps can help to understand how the area has evolved physically and what was on or around

the development site in the past. This can be important in establishing trends in urban form (below), creating a vision for the site and also exploring opportunities for connecting the site with its past.

Views and vistas

New development should respect important landscape, townscape and historic views and vistas.

The proposed solution needs to respond to the site and contextual appraisal – keeping sightlines to specific buildings or trees open or designing in points from which vistas can be enjoyed for example.

Views and vistas in to a development site should also be considered as well as views out.

Streets and spaces

Streets and spaces make up a large proportion of the public areas within a new development and can greatly influence character. Existing characterful features could include for example:

- urban squares
- village greens
- tree lined avenues
- rural lanes with shared surfaces and grass verges abutting the carriageway
- materials such as Staffordshire blue bricks for paving.

Developers are strongly encouraged to take account of and respond to the character of local streets and spaces in their design, dimensions and materials



Staffordshire blue clay bricks and granite threshold strip with historic reference: Swadlincote town centre

when creating new development proposals.

As a predominantly rural District, village contexts are often very relevant. Historical factors can also help to inform the present and it is important to understand the history of local streets and use this to influence design.¹²

In the absence of a strong local character, developers are encouraged to look further afield at good examples within the District or to be innovative in creating appropriate new designs for streets and spaces.

Please refer to the District Council's Open Space, Sport and Community Facility Strategy 2016⁹ for further guidance on open space design.

Urban structure and urban grain

Does the layout and density of the area contribute to local character?

Street layout – are streets arranged and connected in a particular way that forms part of the area's special character?

Plot layout – are plots a certain size and shape – do they combine to create a certain style of street-block and density of development? (e.g. Large blocks in a grid or many tight-knit small blocks organically laid out)

Building position on plot - are buildings positioned on plots in a certain way, is there a consistent building line and/or front boundary treatment? (e.g. Buildings set forward abutting the street or set back with large front gardens and front boundary hedgerows)

Building lines – New development



Figure-ground plan of Melbourne town centre: illustrating the distinctive urban form

should respect historic or traditional building lines, helping to integrate development into the street scene and maintain a continuous urban fabric.

Large developments with limited local context are likely to still need strong building lines on most streets (unless opting for a low density, organic, rural village character with streets defined by landscaping).

Perimeter blocks should contain buildings with live edges, such as front doors facing the street or residential units above shops.

Streets should be defined and characterised by the position of buildings or landscaping, rather than the route and geometry of the highway.

It is recommended that rear garden boundaries that are exposed to public view (e.g. at the side of a property adjacent to the street) do not sit forward of the building line. This helps to preserve the character of the street scene by allowing the attractive windows and doors to be visible and not blocked from view by blank walls that sit forward of the building line.

Boundary treatments – are streets characterised by a certain type of boundary treatment? Continuity along the street can be created by the consistent use of front boundary treatments such as walls, railings and hedges, as well as helping to create characterful streets. Such features can also clearly indicate which spaces are public and which are private.

Rear gardens should not back onto the street, but where the sides of rear gardens are exposed to the public or semi-public realm, a 1.8 m high brick wall should be used as a boundary treatment. This should include detailing such as a coping stone or brick, double tile crease and detail courses as appropriate. Where walls are angled, bricks should be cut and bonded. Fencing will not normally be acceptable in such circumstances.

Buildings on corners should turn the corner well by providing two strong frontages that face the street (dual aspect). Blank or unsightly elevations fronting the street should be avoided.

Scale and massing – Typical local proportions would be a minimum roof pitch of 40 degrees and maximum building depth of 7 metres.

Development should relate to its surroundings and be at a human scale, feeling comfortable to walk near and friendly rather than intimidating. Thought should be given to how the

development will appear at a range of

scales, from standing next to it to viewing it from a long distance.

Contemporary architecture can still relate to traditional scale and massing.

Streets, squares, parks and other



Scropton Road, Hatton: Hedge boundary treatment and side rear garden wall that respects the building line and has good detailing



Traditional scale and massing, 'new' property in Stanton by Bridge

spaces should be enclosed by buildings or trees of the appropriate height, ensuring that a sense of enclosure is achieved and making the space or street feel more comfortable.

Local streets and spaces will have a wide range of widths and will be enclosed by buildings of different heights. The most characterful local examples, however, are likely to have a strong sense of enclosure. For example, with strong buildings set forward on plots abutting the street.

A wider street or space requires a greater building (or tree) height in order to create a sense of enclosure (height to width ratio). The diagram below illustrates the height to width ratios that are recommended if streets and spaces

are to be well defined and enclosed.

A range of street types should be created within a development – taller and stronger building types should be used on the wider streets and overlooking spaces and more minor streets should be narrower and can use smaller scale building types. This also helps people to find their way around.

Architectural style and detailing

When attempting to reference the local context within new developments, it is important to ensure that there is quality in the materials and the detailing and architectural styles and proportions are considered with great care and



Contemporary architecture with traditional scale and massing replicating nearby terraces and sawtooth roofline of nearby industrial units: Rose Hill, Woodville, Swadlincote

attention.

Architectural style is important and defines periods in history. South Derbyshire has a wide variety of architectural styles, from vernacular farm buildings to classical Victorian and Georgian terraces and high quality contemporary architecture.

Most high quality buildings reveal the time when they were designed and built, with the great architects of that particular period setting the fashions and trends.

Although buildings don't have to be designed in any specific style, most tend to be. Common styles include vernacular, classical and modernist. It is not always necessary to create exact replicas of historic buildings – it is possible to take the materials and massing of a vernacular building and use this to create a contemporary building for example.

Thought should be given to the location and overall character of the development and which architectural style is most appropriate.

Visually attractive buildings, streets and spaces often share similar qualities. As

outlined in Quality Reviewer (Urban Design Skills, 2010)¹³, there are certain characteristics of architecture and townscape that are not subjective and can be used to structure assessments:

Detail can be fundamental to quality. Care and skill should be taken in detailing a development as it can help a development to feel human and friendly. Quality detailing applies to both traditional and contemporary architecture.

Consideration should be given to how materials will last over time together

with their maintenance, environmental performance (minimising impact on the environment) and their general quality of appearance.

Proportion – Thought should be given to the relationships between one part of a development and another and the relationship to its surroundings.

Visual attractiveness and the architectural quality of the buildings themselves can, in part, be down to the sizes and shapes of walls and the



Millbrook, Station Road, Melbourne: Classical proportions and rich detailing that relate to local context

Vernacular – local traditional building styles. Can be difficult to authentically replicate as often materials only available locally were used. Replicating vernacular details but at a different scale or inappropriate context can look very poor. If done well, the distinctiveness of a place can be captured.

Classical – classical forms and details can be copied or reinvented – the key is to do this in a manner that is true to the spirit of the original, with a good understanding of the language of classical architecture and ensuring the grammar is correct. In many cases details are missed out, proportions are ignored and attempts fail.

Modernist – Although built forms can be simple, quality of detail is still very important. A great amount of thought is required in design and build quality is paramount. There can be a fine line between a dull, plain building and one that is simple and beautiful. Modernist buildings must also respond to their context and enhance the streetscene but not copy neighbouring styles.

(Quality Reviewer, 2010)¹³

positioning of features such as doors and windows. There are various factors at play, such as the ratio between heights and widths and the proportions between solid (walls) and void (windows, doors). In general terms, with traditional architecture, building proportions with a vertical emphasis (as opposed to square and horizontal) have for a long time created pleasing buildings. Buildings are of course viewed in three dimensions and this also needs to be taken into account, such as the depth of a building, roof pitches, eaves, gables etc.

Order – Order can be a key element of good design. Balance, repetition and symmetry make up order and can also be found in both classical and contemporary architecture. When these characteristics have been got right, there is a pleasing sense of order, there is a positive relationship between the different parts and the whole. Balance creates a pleasing sense that the relationship is right between the parts and the whole. Repetition, although not always essential, can be used as a tool, sometimes unifying a building, street or space and creating drama. Symmetry, again not strictly necessary, can be an effective way of creating order and visually pleasing

Recommendations for traditionally detailed residential development

- Stub cills to ensure that they don't project over stone or chamfered brick cill features and look unsightly);
- Window frames set back in the window opening – fits with traditional window design;
- Wet verges (dry verges with cloaking tiles have a low quality appearance and do not fit into the character of the District);
- Brick or other traditional detailing to eaves and verges;
- Porches, door canopies or surrounds made from timber and tiles (rather than glass-reinforced plastic porches, door canopies or surrounds);
- Roofscape – chimneys on both traditional and contemporary schemes can help to create locally recognisable and/or inspiring roofscapes. Traditionally inspired developments should include chimneys that are authentic in their position on the roof, their scale, construction and detail.

solutions.

3: RESPECT THE EXISTING

Retaining buildings - any older buildings or structures within the site should be assessed with a view to potential conversion. Retained buildings can instantly create a special character, can become key focal points and can be used to inform character themes for the wider site.

4: COMMUNICATE A BUILDING'S FUNCTION

Visual appropriateness and honesty – Unless there is good reason not to do so, the appearance of a building should communicate its function. A building's construction can also be communicated through its design. This can be a good way of celebrating the construction techniques but it may also be necessary to hide features for aesthetic reasons - a good balance should be struck.

different character.

5: RESEARCH NEW CHARACTER

Absence of character - If a development site has no obvious built or landscape character nearby of any merit, effort should be made to explore what could provide a locally inspired identity. The options could include taking cues from the nearest areas to the site that *do* have character and are appropriate to the development site.

The history of the site and the area can provide design cues and historic maps of the site should be studied.

It could also be possible to create a new distinctive character for an area with high quality contemporary architecture that references local character and context through built form, materials and landscaping for example.

Absence of character will not be accepted as an excuse for poor design or nationally generic solutions.

Character areas - larger developments should attempt to create areas of



Cemetery Lodge, Etwall Road, Willington: The adjacent cemetery provided a design cue for this new cemetery lodge, whilst ensuring that its appearance still communicated a private domestic function.

LOCAL CHARACTER AND PRIDE AND VISUAL ATTRACTIVENESS

URBAN STRUCTURE AND URBAN GRAIN

Street and plot layout - streets and plots may be arranged in a particular way that forms part of the areas special character

Building position on plot can help define an areas character - e.g. buildings set forward on a plot or even abutting the street

URBAN STRUCTURE AND URBAN GRAIN

Scale and massing - contemporary architecture can still relate to traditional scale and massing

RESEARCH NEW CHARACTER

In the absence of any characterful local context, new character should be researched and proposed
Larger developments could create areas of different character

URBAN STRUCTURE AND URBAN GRAIN

Scale and massing - Streets and spaces should be enclosed by buildings, enhancing the sense of place and making them feel more comfortable - e.g. buildings with strong frontages and height and/or set forward on the plot

VIEWS AND VISTAS

Identify and then respond to views and vistas, - keeping sightlines open and creating feature views towards key buildings and trees

ARCHITECTURAL STYLE AND DETAILING

Detail - e.g. cills and lintels, chimneys, windows
Proportion - ratio between heights and widths of buildings and sizes and positioning of doors and windows
Order - balance repetition and symmetry can be used to create more characterful and attractive buildings, streets and spaces

ARCHITECTURAL STYLE AND DETAILING

Thought should be given to the location and overall character of the development and which architectural style is most appropriate (e.g. Vernacular, classical, modernist). e.g. if replicating classical styles, this should be true to the spirit of the original, ensuring the grammar is correct (e.g. proportions between heights, widths, doors, windows)

URBAN STRUCTURE AND URBAN GRAIN

Scale and massing - typical local proportions would be a minimum roof pitch of 40 degrees and maximum building depth of 7 metres

URBAN STRUCTURE AND URBAN GRAIN

Building lines - rear garden boundaries exposed to the street should not sit forward of the building line

URBAN STRUCTURE AND URBAN GRAIN

Boundary treatments - can have a big impact on street character - respond to characterful existing examples either adjacent to site or in the local area - e.g. low walls, railings, hedgerows

URBAN STRUCTURE AND URBAN GRAIN

Buildings on corners should turn the corner by providing two strong frontages (dual aspect)

STREETS AND SPACES

Respond to existing characterful features of the area or create new ones - e.g. village green or feature square

URBAN STRUCTURE AND URBAN GRAIN

Building lines - respect historic or traditional building lines adjacent to site or refer to quality examples from the local area - or create strong new building lines

STREETS AND SPACES

Local characterful features should be taken account of and responded to - e.g. grass verge abutting the highway on a rural lane; Staffordshire blue clay paving in a Victorian/Edwardian character setting

LOCAL LANDSCAPE CHARACTER

New development should aim to preserve and enhance local landscape characteristics.

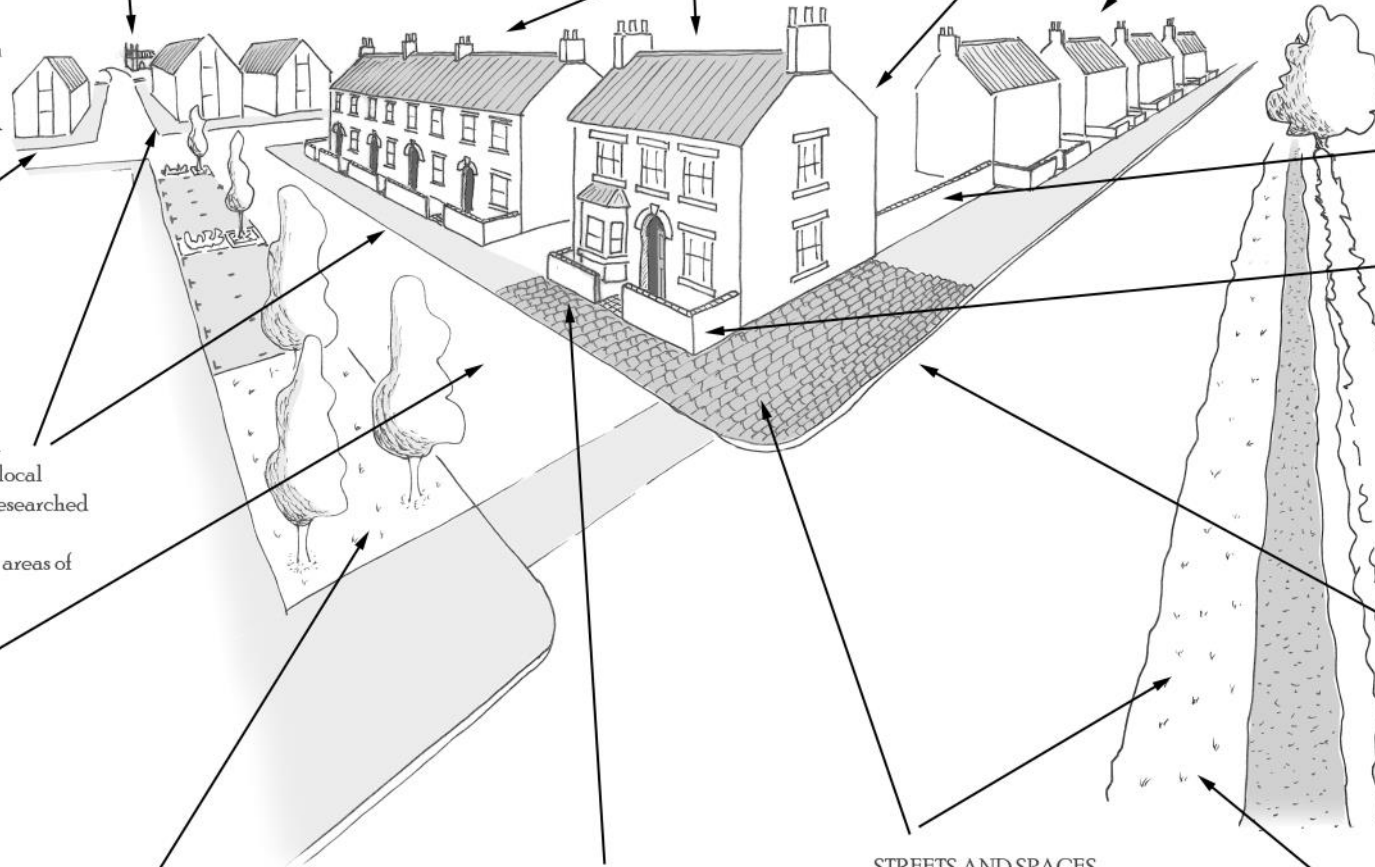

National Forest

BNE1 f) National Forest

Within the National Forest, new development should be encouraged to follow the National Forest Design Charter¹⁴ and the Guide for Developers and Planners¹⁵ and fully reflect the forest context.

Background

The National Forest is one of the country's boldest environmental projects with regional and national importance. This bold vision to transform 200 square miles in the centre of England is not just about tree planting, it's about creating a woodland character and designing for people in a sustainable way.

New development can play a major role in achieving this vision.

The National Forest Design Charter and Guide for Developers and Planners aim 'to create strongly wooded settings for development and a 'treed' theme for public realm and local green space.' Elements of these documents have been included in the guidance below, however for further information, use the links at the end of this section.

The big focus for design in the National Forest is ensuring that a strong forest/ woodland character has been created. The most effective way of achieving this is by using a combination of measures.

Although the National Forest boundary is geographically defined, the character vision and advice within this chapter can apply to the whole District.

Key Actions

1: PROVIDE GREEN INFRASTRUCTURE ON SITE

The guidelines below are a requirement for all new development within the Forest.

Development type	Thresholds	Proportion of site to be Forest green infrastructure
Residential	between 0.5ha and 10ha	20%
Industrial, commercial and leisure	Between 1ha and 10ha	20%
All development	Over 10ha	30%

The green infrastructure referred to in the table above can include creating new, or managing existing areas, for example: woodland, landscaped areas with trees, other wildlife habitats, recreation areas and routes, heritage and landscape features – as appropriate to each site.

2: MAKE TREES PLAY A LEADING ROLE

The Council strongly encourages developers to retain existing trees, hedgerows, woodland and other habitats and make these into features within the development, enhancing them if necessary and ensuring that they are well managed; retained features should be suitably protected during the construction period.

The Council strongly encourages developers to design trees and new woodland into development early in the design process, ensuring that adequate space around them can be achieved. Examples include:

- Street trees: avenues (see C below), single trees in build outs, trees between rows of parking spaces, trees designed in to wider paved areas or courtyards;



Forest Grange, William Nadin Way, Swadlincote: Street trees, hedgerow planting, retained trees and timber posts

- Garden trees in housing schemes – as a general rule, one tree for each property (a free tree could be offered to each new owner with reference to The National Forest);
 - Woodland belts;
 - New spinneys – pockets of wooded greenspace, for example, small blocks of woodland within public open spaces;
 - Feature trees (either new or existing) – large species given space to mature (Oak, Ash, Lime)
- as they require large open spaces;
- Community orchards – local varieties of fruit trees to create new orchards (ideally within new allotments)
- Trees in hard landscapes should be given a chance to grow healthily and tree pits should be appropriately designed (see diagram and Trees in Hard Landscapes guidance referenced at the end of this section).

A tree-lined avenue, with trees adjacent to the carriageway, can have multiple benefits for a development. It can:

- Form the principle street, helping clarify the hierarchy of streets, making it easier to find your way around a large site;
- Form a feature street within a development;
- Create a street that feels narrower to people driving vehicles, encouraging them to drive with more care and attention (see Manual for Streets paragraphs 5.12.3, 7.4.4 and 7.8.6 referenced below);
- Provide greater separation between pedestrians and cyclists and road traffic, making walking and cycling safer and a more pleasant experience (in addition to being greener, more visually attractive and more shaded in hot weather).

3: DESIGN CONTINUOUS GREEN ROUTES

The Council will strongly encourage developers to ensure that green spaces flow and connect with each other so that complete green routes and

networks can be created (greenways with landscaped footpaths and cycle routes). This helps achieve habitat connectivity and improves leisure opportunities and encourages walking and cycling around developments, in addition to making it easier to find your way around and make a mental map of the area.

Access should be provided through new areas of Green Infrastructure (GI) and this should connect to existing public rights of way and other links. Key routes between green spaces or public rights of way should be visibly different (greened) and lead through the development. This can help to encourage exploration of the green

SPECIES GUIDANCE

- **Street tree species recommended - Turkish Hazel (*Corylus Colurna*), Hornbeam (*carpinus fastigiata*)**
- **Front garden boundary hedgerows – any suitable native species, such as; Privet, Hornbeam, Beech**
- **Hedgerows around green spaces and rural edges – native mixed species, Hornbeam, Beech.**
- **To help improve local air quality: Alder, Field Maple, Hawthorne, Larch, Norway Maple, Pine and Silver Birch.**

spaces and also create more successful connections to adjoining National Forest sites.

4: CREATE HIGH QUALITY GARDENS

The Council will strongly encourage developers to invest in front gardens with high quality landscaping (being larger where appropriate) to be designed into schemes. This can help increase overall green coverage around a site, green the streetscape and increase opportunities for social interaction. The planting of appropriate tree species within front gardens can be more viable if there is sufficient distance between the tree and the dwelling.

The Council will strongly encourage developers to provide low (0.6m) hedgerows to front and side gardens on the boundary between public and private land.

Non-native species can establish quicker and look better sooner, making them more likely to be retained by homeowners. Where native species are more appropriate (e.g. green edges, green corridors or fronting Public Open Spaces) planting such hedgerows can be given a better chance of survival by adding a low

basic post and wire fence to protect the young plants as they establish.

Covenants can also be put in place, requiring the property owner to keep the hedge.

5: USE TIMBER AND PLANTING IN CONSTRUCTION

The Council will encourage developers to incorporate timber street furniture (fences, gates, benches, bins, bollards) and timber play equipment into developments. A natural play approach should be adopted to encourage use and exploration of areas of green infrastructure. This could include changes in ground level, fallen trees and boulders to climb on as well as timber play equipment. Play areas should be integrated into the green infrastructure network and not fenced off from it.

Developers are encouraged to showcase timber in building design - such as gallows brackets on porches, exposed rafter feet, barge boards and timber cladding (or timber effect cladding that may be more durable). Timber should be FSC certified.

Developers are encouraged to be innovative and incorporate green walls and green and brown roofs into developments.



Castleton Park, Church Gresley: Timber door canopy



Oakland Village, Swadlincote: Timber used extensively in construction and retained mature trees

6: DESIGN DEVELOPMENTS AROUND SUDS

Sustainable Drainage Systems (SuDS) are of great habitat value and can help to create a green National Forest character, as well as forming greenways through developments, when suitably designed. For example, over ground water courses and swales designed in to a scheme and permanently wet drainage ponds with native wetland planting such areas also form points of interest on footpath routes through green infrastructure.

The Council will expect developers to design SuDS into all schemes (as appropriate to the site and ground conditions). This should be done early on in the design process so that SuDS can be successfully integrated into both the 'hard' and 'soft' parts of the layout.

7: THINK SPECIFICALLY ABOUT WILDLIFE HABITATS

Creation of new habitats (wetlands, reed beds, meadows, heathlands, hedgerows, woodlands) should relate to the ecological character of the site's setting (refer to the National Forest

Biodiversity Action Plan). This should include works in appropriate locations to protect and enhance target species such as: adder, all bat species, lesser spotted woodpecker, barn owl, ruddy darter dragonfly, bluebell, black poplar, otter and water vole. Simple examples include permanently wet ponds for dragonflies and nest boxes for barn owls.

The Council will strongly encourage developers to create wildlife habitats and to think about specific species and the environments within which they will flourish.

Nest boxes for bats and birds such as swifts can easily be incorporated into new developments – both within the landscape and also incorporated into buildings (e.g. forming part of the brickwork – such as the swift brick).

8: ENCOURAGE ACTIVE LIFESTYLES THROUGH DESIGN

Designing places that encourage active lifestyles is a key aim of The National Forest. Continuous green routes and quality open spaces are just two ways that can help achieve this, but there are

many other ways – please see the Healthy Lifestyles chapter for more information.

9: THINK AHEAD

Consider the phasing of landscaping in strategic open space within a large development. Early planting can establish and provide a pleasant setting for later stages of the scheme.

Areas proposed for strategic landscaping should be fenced off and not used for storage compounds where possible. Storage of materials can compact the ground and be detrimental to the establishment of trees and woodland.

Consideration should be given at design stage to the long term ownership and management of open space. Designers should consider maintenance and management costs when designing schemes to ensure these are not prohibitive and that they are understood by the site's owner.

Design of woodland should also incorporate access to allow management works to be undertaken once the woodland has established.

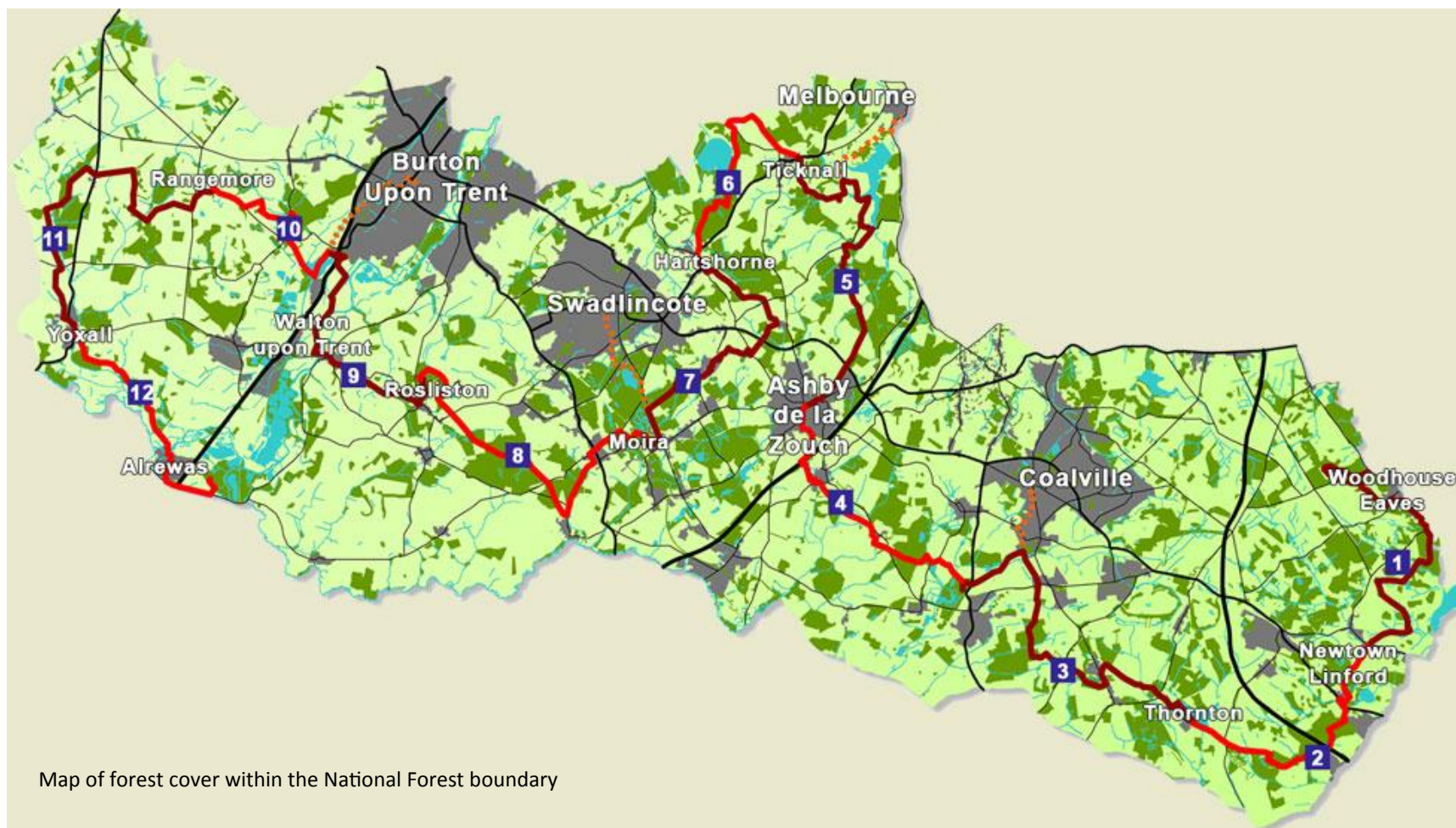

Further resources

Trees and Design Action Group (2014) Trees in hard landscapes : a guide for delivery

NATIONAL FOREST

2: MAKE TREES PLAY A LEADING ROLE
Pockets of woodland
Feature trees

3: DESIGN CONTINUOUS GREEN ROUTES
Green spaces that flow and connect with each other

2: MAKE TREES PLAY A LEADING ROLE
Street trees - tree lined avenue

9: THINK AHEAD
Consider maintenance and management - incorporating maintenance access points.

2: MAKE TREES PLAY A LEADING ROLE
Woodland belts

5: USE TIMBER AND PLANTING IN CONSTRUCTION
Timber street furniture - e.g. fencing, handrails, benches, play equipment.
Green roofs.

4: CREATE HIGH QUALITY GARDENS
Front gardens with high quality landscaping help green the streetscape and increase opportunities for social interaction.

5: USE TIMBER AND PLANTING IN CONSTRUCTION
Showcase timber in building design - e.g. porches and cladding.
Other timber features such as gates

8: ENCOURAGE ACTIVE LIFESTYLES THROUGH DESIGN
Quality green spaces and continuous green walking and cycling routes.

1: PROVIDE GREEN INFRASTRUCTURE ON SITE

7: THINK SPECIFICALLY ABOUT WILDLIFE HABITATS
Create wildlife habitats and think about specific species
For example, wetlands, reedbeds, meadows.
Nest boxes for bats and birds within landscape and on buildings (such as the swift brick)

6: DESIGN DEVELOPMENTS AROUND SUDS
Swales and permanently wet drainage ponds with native wetland planting. Designed early on in the design process.

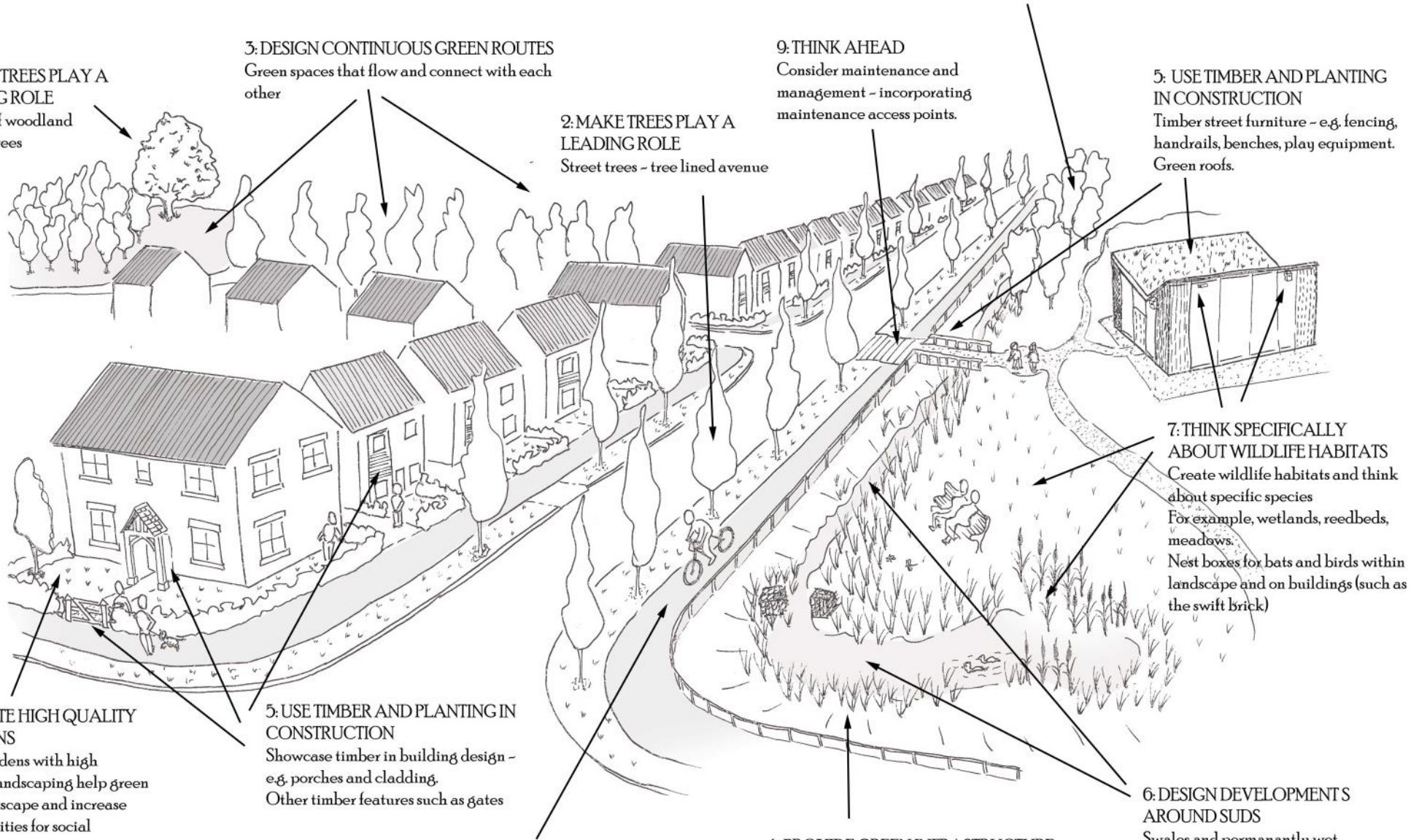

Neighbouring uses and amenity

BNE1 h) Neighbouring Uses and Amenity

New development should not have an undue adverse affect on the privacy and amenity of existing nearby residents or occupiers. Similarly, the occupiers of new development should not be unduly affected by neighbouring land uses.

Background

The Council is committed to the intensive re-use of both previously developed land and to the development of green field sites, where it is deemed necessary to achieve the aims of the Development Plan. In view of this the Council no longer intends to rely on restrictive guidance on the space about and between dwellings within new housing schemes. However, whilst minimum standards will not be applied,

the Council will expect such an approach to be justified by a high standard of design incorporating an imaginative use of space and the provision of attractive areas of open space to create a feeling of place for future residents.

Where new development abuts existing development the Council will seek to ensure that the privacy and amenity of existing occupiers are respected. The following guidelines will be used as a basis for ensuring this is maintained and will be applied where existing occupiers are affected by proposed development. The guidelines aim to retain a reasonable level of privacy for existing occupiers in terms of both direct overlooking and overbearing.

Key Actions

1: CONSIDER OVERLOOKING, OVERSHADOWING AND LIGHT POLLUTION

In order to protect the occupiers of existing dwellings from overlooking and to protect privacy, the primary windows of an existing dwelling should not fall within the minimum distance (as set out in the table below) within the sector of view (see diagram) of the primary windows of the proposed dwelling. Secondary windows to either property will not be considered by this methodology but on the particular merits of the case. Generally, however, such windows will not be protected.

In order to protect existing dwellings from overbearing and to protect outlook, the blank/non-habitable elevation of a proposed two-storey property should not breach the minimum distance within the sector of view from the relevant ground floor primary windows of the existing property. New single storey dwellings will be considered in terms of their effect on existing dwellings, on their own merits.

The guidelines will be applied flexibly to ensure that new sustainable development on adjoining sites is not

unnecessarily constrained.

Where lounge, dining room, kitchen or conservatory windows on a proposed dwelling (or rooms large enough to be considered as such) are located at first floor, greater distances may be required. Such cases are not the norm and will be treated on their own merits. Side windows, including those to a conservatory will be treated as a secondary window. The guidelines assume a relatively level topography and little or no screening. Where this is not the case, the minimum distances may be increased/decreased as appropriate. Where an application is submitted in outline, the Council should be satisfied that the standards set out above could be met. This may require the submission of an indicative plan at the outline application stage.

For dwellings of three or more storeys, greater distances, of the order of 20% more, will be required based on the particular merits of the proposal.

Where there are opposing elevations separated by public areas, such as a highway, and having had regard to the overall character of the surrounding area, the guidelines will usually be

relaxed.

Although most houses overlook neighbouring rear gardens to some extent, areas closest to main windows are where occupants most value privacy. The impact of new development on such private outdoor areas will therefore be assessed on the merits of each case. Balconies serving upper floors will usually create unacceptable overlooking and should be avoided unless they can be effectively screened, or are well away from neighbours.

Sometimes, rear gardens of existing dwellings will be of such a depth that the distances between dwellings will be met regardless of how close to the boundary an opposing new property would be sited. In these circumstances, the presence of first floor primary windows in the new dwelling could lead to a significant loss of privacy to the entire private space of the existing property. In such cases, the Council will seek to ensure that the proposed dwelling is located a reasonable distance from the garden boundary of the existing dwelling.

The use of out of hours night time lighting should be minimised. Where lighting is required for security and/or

community safety, downward directed, vandal resistant, energy efficient light units should be installed. Increased light pollution from car park and security lighting may cause disturbance to the local community. Lighting should not be placed next to wildlife habitats or where the light columns would appear above a prominent topographical ridge line.

2: THINK ABOUT QUALITY OF LIFE

The provision of secure private space is an effective way to improve the quality of the occupier's life. Private space can be adaptable and can serve as a multi-purpose area, for example as a secure playing space for children, for horticultural purposes, or simply as a convenient place for fresh air.

Developers are strongly encouraged to improve the occupier's quality of life by providing an outdoor space for their use, which is at least partially private.

Distance Guidelines

NEIGHBOURING DWELLING

All distances in metres

P R O P O S E D D W E L L I N G O R E X T E N S I O N		Lounge/dining room	Kitchen	Bedroom/study (first floor)	Bedroom/study (ground floor)	Conservatory
	Lounge/dining room	21	21	15	18	21
	Kitchen	21	21	15	18	21
	Bedroom/study (first floor)	21	21	15	18	21
	Bedroom/study (ground floor)	18	18	12	15	18
	Conservatory	21	21	15	18	21
	Blank elevation	12	12	No minimum	9	9

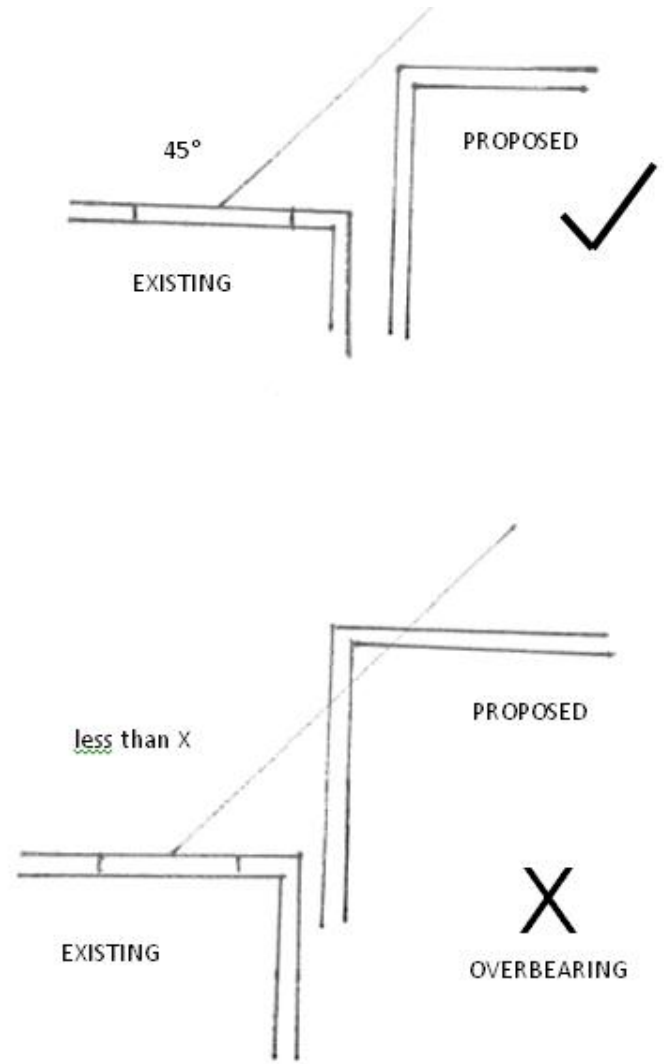
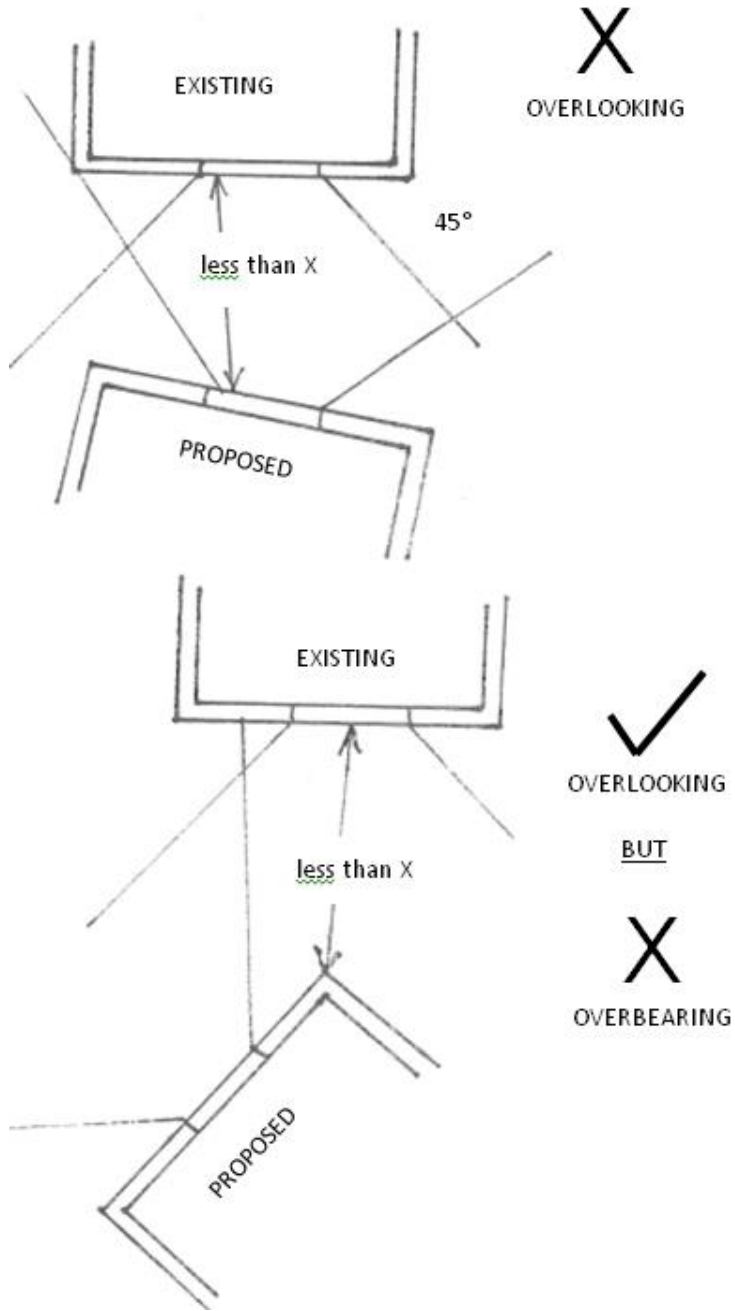

Amenity distance diagram

Cross boundary collaboration

BNE1 i) Cross Boundary Collaboration

New areas of growth that span administrative, land ownership, developer parcel or phase boundaries should be considered and designed as a whole through a collaborative working approach.

Background

Many large development sites span local authority and developer boundaries. This provides an opportunity to plan ahead and design parcels of development that work together to create complete new neighbourhoods. This is vitally important in creating successful residential areas and also in meeting the requirements of many of the other

Design Principles within this guidance.

There are many development sites where collaboration has not taken place and this has created unnecessary physical divides between neighbouring communities, jeopardised longer distance pedestrian and cycle routes across sites and led to fragmented and confused character areas. Towns and cities cannot grow successfully and sustainably in this way and people's quality of life is lowered as a result.

This is partly a call for developers to work together and share an interest in the wider issues beyond their red line. It is also a call for neighbouring Local Planning Authorities to work together and to be more proactive in masterplanning large sites.

This is essential as when it comes to the design of the individual developer parcels / planning applications, there is more certainty about the strategic issues. It also avoids major opportunities being completely

overlooked.

Key Actions

1: CREATE QUALITY URBAN DESIGN GUIDANCE

Where new areas of development span Local Authority administrative or developer boundaries, joint collaborative working between Local Planning Authorities and also between different developers will be encouraged.

Local Planning Authorities and developers should create and agree upon a plan that unifies the full extent of the new neighbourhood or commercial area, making sure that it also knits in to surrounding areas. This plan could take the form of an Urban Design Framework, Masterplan or Development Brief, as appropriate.

Design codes could also be used to aid coherence, provide more detailed and precise guidance and help achieve a more consistent design quality.

In some instances, a joint, multi-site, cross-boundary design review will be appropriate in the assessment of development proposals.

2: PROTECT FUTURE LINKS

In order to adhere to the Design Principles within this policy, with particular reference to movement, legibility and community cohesion, land ownerships and development sites should not prejudice the development of neighbouring land, create landlocked sites or restrict connections.

Where opportunities exist, developers must provide links to adjacent streets, paths and the wider area. If third party land ownership issues prevent these links from being established, the potential to provide these links in the

future must be safeguarded by the careful placement of buildings, street alignment and extent of the adoptable highway.

If potential links are not included within development proposals, the applicant should demonstrate through the provision of evidence that this is due to circumstances beyond their control. Where future-proofed links are provided to adjacent land, the land up to the edge of the site boundary must be offered for adoption.

3: CREATE CONNECTED INFRASTRUCTURE

There are also further efficiencies that can be made through cross-boundary collaboration, such as shared open spaces and linked SuDS schemes.

Types of Urban Design Guidance¹⁶

Urban design frameworks – broad principles for an area of change

- Long term guidance for large areas that describes and illustrates how planning and design policies and principles should be implemented in an area where there is a need to control, guide and promote change;
- Provides a two-dimensional vision of future infrastructure requirements;
- Relates to areas likely to have several developers and phases, only part of which likely to be developed in the near future;
- Used to coordinate more detailed development briefs and masterplans.

Development briefs / Design briefs – more detailed guidance for a specific site

- Provides guidance on how a specific site of significant size or sensitivity should be developed in line with the relevant planning and design policies;
- Often contains indicative, but flexible, vision of future development form;
- Covers a site that most of which will be developed in the near future.

Masterplans – detailed guidance for a site, including a detailed three-dimensional vision, implementation, costs, phasing and timing

- A document that charts the masterplanning process and explains how a site or series of sites will be developed;
- It will describe how the proposal will be implemented and set out the costs, phasing and timing of development;
- Usually prepared by or on behalf of an organisation that owns the site or controls the development process;
- Sets out principles on matters of importance rather than prescribe in detail how development should be designed;
- Should however show in some detail how the principles are to be implemented.

Design Codes

- A document that includes detailed drawings or diagrams that sets out with some precision how the design and planning principles should be applied to development in a particular place;
- Can be included within an urban design framework, development brief or masterplan when a degree of prescription is appropriate.

Healthy lifestyles

BNE1 j) Healthy Lifestyles

New development should address social sustainability issues, by supporting healthy lifestyles, including through the promotion of active travel, the provision of public open space, sports and other leisure facilities.

Background

The lifestyles of people in the UK are becoming increasingly less healthy and more inactive. One in two women and a third of men are not active enough and physical inactivity is responsible for 1 in 6 deaths in the UK (Public Health England, 2014)¹⁸.

Physical inactivity has adverse effects on health, wellbeing and quality of life at all ages and across all sectors of

society, but particularly affects vulnerable groups such as in lower social groups. Internationally, the UK has higher levels of inactivity than other similar countries.

“The financial costs of this inactivity are estimated to be £7.4 billion per year” (Public Health England, 2014).

Behavioural patterns, such as lifestyle, and social circumstances, including housing, have a major impact on health. Health and life expectancy are largely determined by factors that can be changed (Figures 1 and 2).

Figure 2 illustrates that 79% of factors that determine health and life expectancy are related to how we live (behaviour and social circumstances).

Figure 1: What determines health and life expectancy²⁰

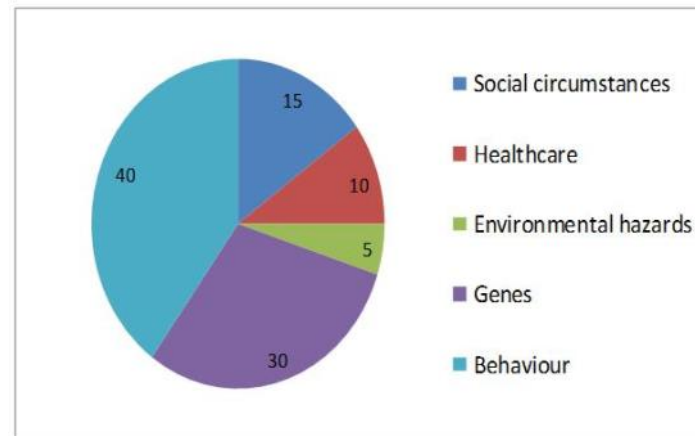
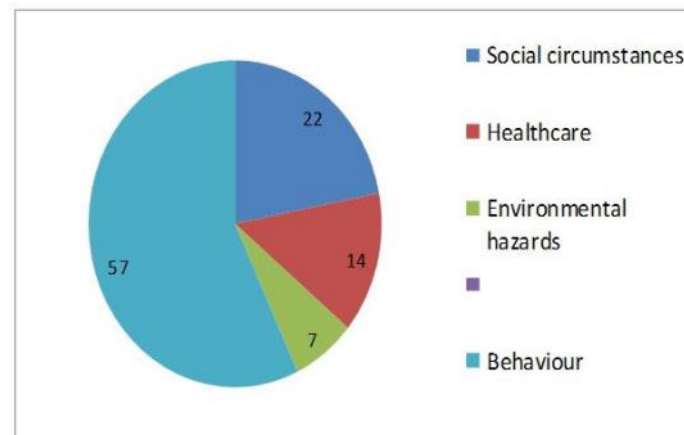

Figure 2: What determines health and life expectancy that we can actually change²¹



Environmental factors such as air pollution also have a major impact on health. Air pollution is the largest contributor to the burden of disease from the environment that can impact on the whole population. Current evidence indicates that air pollution is associated with cardiovascular disease, lung cancer, respiratory disease, asthma and stroke. Air pollution disproportionately affects the young, older people, those with underlying cardiopulmonary conditions and the most deprived within our communities.

Actions that improve local air quality can deliver public health benefits across entire local authority areas.

Please see Appendix F for background information on air pollution.

The way that new development is designed has a major opportunity to influence behaviour, social circumstances and environmental factors such as air quality.

Sport England have acknowledged that there is a close relationship between

the design and layout of where we live and people's health with a detailed report: Active Design: Planning for health and wellbeing through sport and physical activity¹⁷. This report includes 10 Active Design Principles that all relate closely to this Design SPD.

The environments within which people live can have a big influence on the lives that they live.

Healthy lifestyles can be encouraged by ensuring that new residential developments are designed for physical activity and to create opportunities for contact with both nature and other people.

Key Actions

The topic of healthy lifestyles is a theme that cuts across many chapters in this Design SPD. Where crossover exists, the relevant sections of this Design SPD have been signposted.

1: DESIGN FOR PHYSICAL ACTIVITY

Poorly designed buildings and

residential areas can discourage people from walking, cycling and visiting open spaces and key services and facilities. This may be because the routes are unattractive or perceived to be dangerous or simply because destinations are too far away.

Designing for physical activity involves actively encouraging people to walk, cycle and visit open spaces more by making it attractive to do so.

Streets should be pleasant and safe to walk or cycle along and should lead directly to nearby destinations containing open spaces and key services and facilities.

Walking and cycling routes should form connected networks within development sites whilst also connecting to routes and destinations beyond the site.

Streets and public open spaces should be accessible to all, designed to a high standard, being flexible and multifunctional.

The related chapters of this document include:

Community safety

- 1) Increase visibility
- 3) Create safe street networks

Street design, movement and legibility

- 1) Create high quality streets and spaces
- 2) Design for walkability
- 3) Promote cycling
- 4) Design for slow speeds
- 5) Create a navigable place
- 6) Create connected neighbourhoods
- 7) Deliver viable public transport routes

Ease of Use

- 1) Design places that can be used by all
- 3) Consider demographics
- 4) Be prepared for change

National Forest

- 4) Design continuous green routes
- 9) Encourage active lifestyles through design

Cross boundary collaboration

- 2) Protect future links
- 3) Create connected infrastructure

2: CREATE OPPORTUNITIES FOR CONTACT WITH NATURE

Attractive natural environments can be beneficial to both physical and mental health. They could include large parklands rich with attractive plants, trees and wildlife or simply involve a street with trees and well landscaped front gardens.

The related chapters of this document include:

Street design, movement and legibility

- 1) Create high quality streets and spaces

Local character and pride**1) Consider all aspects of local character:**

Landscape character areas; Local landscape character; wildlife habitats; Sustainable Drainage Systems; Views and vistas; Streets and spaces.



Cycle route in the National Forest

National Forest

- 1) Provide green infrastructure on site
- 2) Make trees play a leading role
- 3) Design continuous green routes
- 4) Create high quality gardens
- 5) Use timber and planting in construction
- 6) Design developments around SuDS
- 7) Think specifically about wildlife habitats
- 8) Think ahead

Resource use

- 1) Encourage people to compost household waste

3: POSITIVE SOCIAL CONTACT

This is about creating more opportunities for people to meet and for communities to develop and strengthen.

Increasing positive social contact is beneficial for mental health, which in turn, can raise the likelihood of increased physical activity.

The way in which environments are designed can open up opportunities for increased social contact. For example, concentrations of services and facilities

such as schools, shops, community centres and public open space increases the likelihood of people meeting people they know or striking up conversations with other members of the community.

Another example would be on-street parking and/or well landscaped front gardens, increasing the likelihood of people communicating with one another on the street where they live.

Quality public realm can also encourage better quality social contact, for example, a wider (3m or over) pavement width separated from passing vehicles by a grass strip and street trees creates a more comfortable environment within which to stop and talk. Conversely, a conversation held on a 2m pavement close to passing traffic and with fear of obstructing other pedestrians is likely to be less comfortable and shorter.

The related chapters of this document include:

Diversity and community cohesion

- 1) Encourage a sense of belonging and community togetherness
- 2) Create diverse places where people can meet
- 3) Integrate local centres in to the townscape
- 4) Design streets and public open spaces for the whole community

Ease of Use

- 1) Design places that can be used by all
- 3) Consider demographics

4: DESIGN FOR CLEANER AIR

The Council will encourage developers to design developments that attempt to minimise air pollution levels by following the advice below:

- Include Electric Vehicle recharging infrastructure within the development (wall mounted or free standing in-garage or off-street points);

- Provision of green infrastructure—in particular the use of appropriate tree species to improve local air quality including Alder, Field Maple, Hawthorne, Larch, Norway Maple, Pine and Silver Birch.
- Although chimneys are encouraged in the Local Character and Pride section, fixed solid fuel combustion appliances can be detrimental to air quality;
- Provision of ground source heat pumps (gshp) for heating internal spaces and water. Where gshp are not technically viable, use air source heat pumps;
- Providing new residents with a welcome pack with information and advice about reducing air polluting travel behaviour—including promoting for example walking, cycling, public transport and car-sharing opportunities;

RECOMMENDED WALKING DISTANCE GUIDELINES

In terms of children’s play, the distances considered reasonable to travel from home to public open space

are set out below. These distances are based on the National Playing Fields Association (NPFA) recommendations:

- **Toddler Play Area LAP -**
Within 200m (1/8 mile)
- **Children’s Play Area LEAP**
Within 400m (1/4 mile)
- **Small Local Park -**
Within 800m (1/2 mile)
- **Local Park NEAP -**
Within 1200m (3/4 mile)

With regards to recommended maximum walking distances to other destinations, clear guidance is limited. The typical walking distances and times below can be used to decipher what distance and length of time people would be prepared to walk to a given destination, before they would be put off and decide to either not make the trip or to travel by car.

A common sense approach should be

taken in assessing this, being mindful of the challenge that exists in encouraging people to walk instead of drive and the need to have key services and facilities as close as possible to the majority of people’s homes. The needs of everyone in society also need to be taken into consideration – for example, an elderly person heavily reliant on public transport shouldn’t have to walk for more than 400m in order to catch the bus. Similarly, someone deciding whether to get the bus or drive could be put off from getting the bus if the bus stop were a long way away (over 400m).

250 m	=	2-3 min walk
400 m	=	5 min walk
800 m	=	10 min walk
1,200 m	=	15 min walk
1,600 m	=	20 min walk

Source: South Derbyshire District Council’s Open Space, Sport and Community Facility Strategy 2016).

Further resources

- [Urban Air Quality, Woodland Trust, 2012](#)
- [Air pollution: outdoor air quality and health \(Draft 2016\) \(final version expected June 2017\)](#)

Resource use

BNE1 K) Resource Use

New development should be designed to facilitate the efficient use of resources and support the reuse and recycling of waste throughout the lifecycle of all developments from design, construction, use and after use. New development should provide adequate space for the storage of waste and where necessary, the treatment and collection of waste.

applicants to seek solutions, which mean that proposals secure development that improves the economic, social and environmental conditions in the area.'

Policy S3 states that 'The Council will support developers in bringing forward more sustainable homes and commercial properties by supporting the Government's drive towards improved housing standards including in respect of access, space standards, security, water and external waste storage...'

leachate and methane gas. Leachate is a toxic liquid, which can pollute water and soil. Methane is explosive and is also a greenhouse gas (27 times more powerful than carbon dioxide). Around 30% of waste collected in South Derbyshire (around 290kg per household annually) is diverted from landfill by composting. Compost can be used in the garden as a conditioner and mulch as an alternative to peat based compost extracted from natural wildlife sites. However whilst all households in South Derbyshire have access to the Council's mixed garden and food waste collection service, the environmental benefits of composting can be improved where households compost at home. The use of compost bins can reduce the amount of garden waste generated by around one third or 100kg per household per year and so could significantly reduce the amount of waste collected and treated through the Council's kerbside scheme.

Key Actions

1: ENCOURAGE PEOPLE TO COMPOST HOUSEHOLD WASTE

Composting at home is one of the easiest, most effective and environmentally friendly ways of recycling organic waste. Organic waste in a landfill site degrades to form

The District Council recommends that developers play an active role in encouraging residents to compost organic household waste. The Council will work collaboratively with developers

Background

At its very heart, the NPPF supports the presumption in favour of sustainable development. The District Council's Local Plan in turn also adopts this approach. Policy S2 states that the Council will 'work proactively with

who seek to improve the sustainability of new dwellings, particularly through the use of no or low cost measures. Clearly the provision of compost bins within new dwellings with gardens is such a measure. For the price of a compost bin, often around £20 per property, a reduction in the total volume of household waste of around a tenth and around one third of mixed garden and food waste can be achieved for each household that takes up composting.

Any composting facilities provided should be suitable for normal domestic, non-woody garden, food and other compostable household waste. All facilities should be accompanied by information explaining how they work.

2: REDUCE DEMAND FOR WATER

Policy SD2 (Sustainable Water Supply, Drainage and Sewerage Infrastructure) requires that water consumption in new homes is no more than 110 litres per person per day (including outside usage). This is because the Part 1 Local Plan invokes the Optional requirement set out in Part G of the

Building Regulations (2015). Further detail on local water requirements and the justification for applying the Option Standard across the whole of South Derbyshire are set out in the Part 1 Local Plan.

In addition house builders can get up to a 100% discount on clean water infrastructure charges levied by Severn Trent where it can be demonstrated that new homes are built to the 110 litres per person per day. Further information on this discount scheme can be viewed on Severn Trent's website at:

<https://www.stwater.co.uk/building-and-developing/regulations-and-forms/application-forms-and-guidance/infrastructure-charges/>

3: EMBRACE SOLUTIONS FOR SUSTAINABLE ENERGY AND POWER GENERATION

The Council recommend that development proposals are designed to be forward thinking in their approach to energy and power generation.

Developers are strongly encouraged to include solutions such as photovoltaic panels and solar panels or design

buildings in a way where future households can accommodate renewable energy measures in the future.

Provision of ground source heat pumps (gshp) for heating internal spaces and water will also be encouraged. Where gshp are not technically viable, air source heat pumps could be used.

Links to other documents:

[Home Composting Diversion: Household Level Analysis: Wrap](#)

[Approved Document G | Part G - Sanitation, hot water safety and water efficiency | Planning Portal](#)

Design guidance for non-domestic development

COMMUNITY SAFETY

Increase visibility

The siting and design of new buildings should maximise surveillance along streets, spaces, car parks and pedestrian routes. Buildings should be sited to allow windows and entrances to overlook streets and other pedestrian routes within or adjacent to the site.

All open spaces which include car parks, cycle stores and seating areas should be well observed from within the buildings and evenly lit at night when in use.

Building design or landscaping should not restrict surveillance of pedestrians or provide places to hide alongside

pedestrian routes. Buildings or walls should not provide unnecessary set backs or recessed areas. Planting alongside pedestrian routes should be very low growing.

As a general recommendation, where good visibility is needed, shrubs should be selected to have a mature growth height of approximately 1 metre or under and trees should ideally have no foliage, epicormic growth or lower branches below 2 metres.

A mix of uses should be considered in any development area to promote activity and surveillance over an extended period of the day and week. A mixture of industrial, commercial and ancillary uses can all increase pedestrian and vehicular activity, and with it surveillance.

Separate service yards should be provided with secure boundaries and

gated accesses. These areas, including outbuildings for plant, refuse areas and service yards are often vulnerable to break in. They should be designed so as not to obscure doors or accesses to the main building or to allow access onto roofs. Provision of good external lighting and surveillance from the main building will enhance security. All main entrances into the buildings should be well overlooked and well-lit when in use after dark.

Buildings should be located on the edge of sites to enclose and overlook public streets, car parking and open spaces, creating a strong urban form and active frontages in the public realm. The only exception to this would be (i) where it has been agreed that the development of an exceptionally high quality building located within very well landscaped parkland is appropriate, (ii) where it has been agreed that a green edge or buffer is to be created alongside wildlife sites or open

countryside.

Define the public and private

The public realm (roads, streets, and spaces) is shared by all, even in industrial estates. The way in which buildings, plots, and their activities relate to the street can impact upon all users of the public realm. In addition to this, the 'business' of an industrial or commercial activity should be able to occur within the private realm without it adversely affecting other people or the general environment.

Wherever possible, therefore, the layout and design of new industrial and commercial plots will be expected to front buildings onto the public realm and to enclose 'private' external spaces, such as yards and car parks, behind them.

Buildings have traditionally provided the most effective way of screening public from private spaces. When applied consistently, frontage buildings can help to produce a layout based on 'perimeter blocks'.

Create safe street networks

Industrial and business development

adjacent to **public rights of way** should, wherever possible, avoid detriment to the environmental quality or safety of the path, for example through the creation of potential ambush points, as this may deter use by pedestrians.

For security reasons there should normally be only one vehicular access to the premises and this should ideally have a barrier.

STREET DESIGN, MOVEMENT AND LEGIBILITY

Encourage travel on foot, by bike or by public transport

Industrial sites – although not traditionally thought of as having high place-making needs, travel by public transport, on foot or by bike to industrial sites needs to be encouraged and the environment needs to make travel by these modes safe and easy to do.

A reduction in car use can be achieved by:-

- Provision of convenient, short, direct pathways to the main entrances.

- Ensuring the development is directly served by adequate public transport services.
- Provision of secure covered cycle stores near entrances and adjacent to overlooking windows.
- Provision of changing and showering facilities for cyclists.
- Provision of on and off site cycleways to enable connection to the city cycle network.
- Improved customer care in terms of delivery of goods and services to assist non car users.
- Using commuter planning measures which reward car sharing, car pool for employees, cycling, walking and the use of public transportation.

Charging points for electric vehicles should also be considered.

All roads throughout a site should have wide and continuous footpaths and pavements with safe accessible crossing points at road junctions. These footpaths or pavements should provide access between buildings and public open spaces and be linked into other pedestrian routes within and beyond

the site.

Adequate lighting must be provided along all publicly accessible streets and pathways within the development and on routes between these and main entrances and within car parks.

Legible and connected streets

As a general principle, road layouts for industrial estates should avoid the use of culs-de-sacs wherever possible.

A clear relationship between any new development and its surroundings must be established. Generally, any new layout should be fully integrated into the surroundings by linking and aligning roads, public transportation and landscape features, and reinforcing key elements of the townscape along streets.

Car parking

For the amount of car parking spaces required refer to the latest version of 6C's Design Guide.

EASE OF USE

Ensure that car parks and routes to and from them are easy to understand and accessible to all.

Commercial units should be able to adapt to changing needs and uses. Careful thought should be given to the location of large format retail units, particularly within established town and village settings.

Commercial developments must be designed to take full account of potential opportunities for change, once the original occupier has vacated the site.

Developers are encouraged to install sprinkler systems in to new properties. Alternatively, measures should be taken to assist with future installation.

The design of buildings should allow for the possibility of some adaption and flexibility, since the needs of future users can never be fully anticipated. Ensuring that the internal layout, position of entrances, stairs and methods of construction allows for some flexibility in its use will enhance its life expectancy and long term value.

Bin storage areas should be located out of public view and located practically to encourage use.

LOCAL CHARACTER AND PRIDE AND VISUAL ATTRACTIVENESS

Landscape setting

Good opportunities exist for creating commercial developments with landscaping schemes that knit a development in to the surrounding landscape setting.

Development sites that are set within a landscape context should take account of the character of the surrounding landscape. Appendix F illustrates the different landscape character areas within Derbyshire.

The Council strongly encourages new development to be designed to respect and knit in to these landscape character areas – helping to protect and enhance these valued, locally distinctive landscapes and wildlife habitats.

More detailed information and guidance can be found in the Landscape Character of Derbyshire document (fourth edition, March 2014) - <http://www.derbyshire.gov.uk/environment/conservation/landscapecharacter/>

The character vision for the National Forest should also be taken into account – see the National Forest section of this Design SPD.

Small, narrow and isolated planting areas are of limited value, and will be ineffective in creating a landscape framework. Existing tree belts and hedgerows can be important features around which to structure the layout of new development. Their retention can be essential in locations where industrial development can be seen from distant public viewpoints and the existing landscape setting needs to be protected or enhanced.

Boundary landscaping should use native species appropriate to the location and should generally avoid unmanaged conifer hedging, particularly in rural areas.

The landscape design should enhance and extend existing features. Planting should not necessarily be evenly distributed around the new buildings, but should be concentrated to maximise the impact in the areas best placed to benefit from it. For example, it could be used to enhance: water courses, rock outcrops, ponds, hedges, woodland, grassland, shrubland, site boundaries, public open space, recreational paths and/or avenue planting.

It is expected that the design approach for the majority of industrial development in the rural areas will be one that seeks to contain buildings and sites within the existing topography and landscape, appropriately enhanced where necessary.

Large development sites, both greenfield and brownfield, should make a significant contribution to the creation of a diverse urban landscape by maximising areas of woodland, shrub, wetland and wildflower rich grasslands.

The wildlife value of the site as developed should be maximised. This can be achieved by:

- preserving and enhancing existing wildlife habitats;
- including and protecting wildlife habitats which may exist along the margins of the proposed

development site;

- assessing existing buildings for signs of wildlife habitation;
- Designing buildings with integral nesting or roost sites;
- protecting root and water systems of retained trees, hedges, shrubs and important grassland from compaction and the impact of temporary or permanent construction works;
- protecting existing wildlife networks including green corridors;
- careful management of undeveloped land to avoid damage during development;
- planting native species in newly landscaped areas.

Architecture

New buildings should be of high quality contemporary design, appropriate for the use and context. The design of any building, even the simplest industrial shed, should always make some positive visual contribution to its environment.

Local materials can be used on larger or non-domestic buildings – such as red

brick, render, timber or clay tiles.

Contemporary and innovative architecture that subtly references local character is encouraged.

The visual impact of colours and finishes of wall and roof cladding materials should be considered in relation to the background and context of the building. Their impact on the townscape or landscape should also be assessed in long views and views from higher ground. Generally more subdued and non-reflective finishes will reduce the overall impact of a

building. Colour contrast and highly reflective materials may be used to highlight key features such as entrances, windows and structure. However, where a landmark building is considered appropriate, the use of contrasting materials and colours may be justified.

High quality design solutions do not necessarily involve greater costs. Through the perimeter block form of development, architectural attention can be concentrated on building fronts,

where it has most impact upon the public realm. In addition, perimeter blocks provide a development structure within which a wide range of architectural styles can be accommodated. The underlying objective for the architectural design of industrial and commercial buildings should be the same as for all new development, which is to make the public places in which they stand as attractive and welcoming as possible. The architectural treatment of industrial and commercial buildings should play its part in improving the image of new development in the District.



The Pipeworks, Swadlincote: retained and renovated buildings and high quality contemporary architecture

NATIONAL FOREST

Provide green infrastructure on site

The guidelines below are a requirement for all new development within the National Forest.

Development type	Thresholds	Proportion of site to be Forest green infrastructure
Residential	between 0.5ha and 10ha	20%
Industrial, commercial and leisure	Between 1ha and 10ha	20%
All development	Over 10ha	30%

The green infrastructure referred to in the table above can include creating new, or managing existing areas, for example: woodland, landscaped areas with trees, other wildlife habitats, recreation areas and routes, heritage and landscape features – as appropriate to each site.

Make trees play a leading role

The Council strongly encourages developers to retain existing trees, hedgerows, woodland and other habitats and make these in to features within the development, enhancing them if necessary and ensuring that they are well managed. Retained

features should be suitably protected during the construction period.

The Council strongly encourages developers to design trees and new woodland into development early in the design process, ensuring adequate space around them can be achieved. Examples include:

- Street trees: avenues (see C below), single trees in build-outs and trees within car parks;
- Woodland belts;
- New spinneys – pockets of wooded greenspace, for example, small blocks of woodland within public open spaces;



Nestle factory, Hatton: Green Wall at site entrance

- Feature trees (either new or existing) – large species given space to mature (Oak, Ash, Lime) require large open spaces;

Trees in hard landscapes should be given a chance to grow healthily and tree pits should be appropriately designed (see diagram and Trees in Hard Landscapes guidance in references).

Design continuous green routes

The Council will strongly encourage developers to ensure that green spaces flow and connect with each other so that complete green routes and networks can be created (greenways with landscaped footpaths and cycle routes). This helps achieve habitat connectivity and improves leisure opportunities and encourages walking and cycling around developments, in addition to making it easier to find your way around and make a mental map of the area.

Access should be provided through new areas of Green Infrastructure (GI) and this should connect to existing public rights of way and other links. Key routes between green spaces or

public rights of way should be visibly different (greened) and lead through the development. This can help to encourage exploration of the green spaces and also create more successful connections to adjoining National Forest sites.

Use timber and planting in construction

The Council will encourage developers to incorporate timber street furniture (fences, gates, benches, bins, bollards) and timber play equipment into developments.

Developers are encouraged to showcase timber in building design, for example timber cladding (or timber effect cladding that may be more durable). Timber should be FSC certified.

Developers are encouraged to be innovative and incorporate green walls and green and brown roofs into developments.

Design developments around SuDS

Sustainable Drainage Systems (SuDS) are of great habitat value and can help to create a green National Forest character, as well as forming greenways through developments,

when suitably designed. For example, overground water courses and swales designed into a scheme and permanently wet drainage ponds with native wetland planting. These also form points of interest on footpath routes through green infrastructure.

The Council will expect developers to design SuDS into all schemes (as appropriate to the site and ground conditions). This should be done early on in the design process so that SuDS can be successfully integrated into both the 'hard' and 'soft' parts of the layout.

Think specifically about wildlife habitats

Creation of new habitats (wetlands, reedbeds, meadows, heathlands, hedgerows, woodlands) should relate to the ecological character of the site's setting (refer to the National Forest Biodiversity Action Plan). This should include works in appropriate locations to protect and enhance target species such as: adder, all bat species, lesser spotted woodpecker, barn owl, ruddy darter dragonfly, bluebell, black poplar, otter and water vole. Simple examples include permanently wet ponds for dragonflies and nest boxes for barn owls.

The Council will strongly encourage developers to create wildlife habitats

and to think about specific species and the environments within which they will flourish.

Nest boxes for bats and birds such as swifts can easily be incorporated into new developments, both within the landscape and also incorporated into buildings (e.g. forming part of the brickwork, such as the swift brick).

NEIGHBOURING USES AND AMENITY

The impact of new buildings on neighbouring properties in terms of their effect on sunlight and on daylight should be minimised.

The use of out of hours night time lighting should be minimised. Where lighting is required for security and/or community safety, downward directed, vandal resistant, energy efficient light units should be installed. Increased light pollution from car park and security lighting may cause disturbance to the local community. Lighting should not be placed next to wildlife habitats or where the light columns would appear above a prominent topographical ridge line.

CROSS BOUNDARY COLLABORATION

Where new areas of development span Local Authority administrative or developer boundaries, joint collaborative working between Local Planning Authorities and also between different developers will be encouraged.

Local Planning Authorities and developers should create and agree upon a plan that unifies the full extent of the new neighbourhood or commercial area, making sure that it also knits in to surrounding areas. This plan could take the form of an Urban Design Framework, Masterplan or Development Brief, as appropriate.

In some instances, a joint, multi-site, cross-boundary design review will be appropriate in the assessment of development proposals.

HEALTHY LIFESTYLES

Sport England's 10 Active Design Principles (Active Design, 2015)¹⁷ relate closely to this section and are listed below:

1. Activity for all
2. Walkable communities
3. Connected walking & cycling routes

4. Co-location of community facilities
5. Network of multifunctional open space
6. High quality streets & spaces
7. Appropriate infrastructure
8. Active buildings
9. Management, maintenance, monitoring & evaluation
10. Activity promotion & local champions

Design for physical activity

Poorly designed buildings and built environments can discourage people from walking and cycling to work. This may be because the routes are unattractive or perceived to be dangerous or because cycle parking and changing facilities are inadequate or not provided at all.

Walking and cycling routes should be provided for all non-domestic developments and these should be safe, well lit, direct and follow best practice design guidance^{4, 5, 6, 7}

Routes should form connected networks within development sites whilst also connecting to routes and destinations beyond the site.

New developments should, where appropriate, include staff travel plans that are put in to practice. Cycle parking, lockers and changing facilities should be provided. Cycle parking areas should be overlooked (natural surveillance), covered and lit.

Create opportunities for contact with nature

All development in the district should include high quality landscaping appropriate to the location and type of development. For non-domestic developments this could include designing trees, SuDS, wildlife habitats and other landscape features such as green spaces with seating in to the scheme.

Positive social contact

Developers are encouraged to design schemes that help to encourage social contact. This could include for example the provision of attractive communal seating areas to take breaks / eat lunch, notice boards, outdoor seating areas, mixed use schemes, quality public realm.

Design for cleaner air

The Council will encourage developers to design developments that attempt to minimise air pollution levels by following the advice below:

- Include Electric Vehicle recharging infrastructure within car parks and for commercial vehicles (where appropriate);
- Provision of green infrastructure— in particular the use of appropriate tree species to improve local air quality including Alder, Field Maple, Hawthorne, Larch, Norway Maple, Pine and Silver Birch.
- Prepare Staff travel plans

RESOURCE USE

On industrial plots there are often large expanses of hard paving, and it will be expected that the detailed design and layout of such areas will increasingly embrace engineering concepts such as Sustainable Drainage Systems (SuDS).

Industrial buildings also often have large expanses of roof that are ideal for rainwater capture and grey water recycling, particularly where the industrial processes involve heavy water consumption. Large roof

expanses also offer opportunities for exploiting solar energy. Green roofing may also be appropriate for the flat roofs of industrial buildings.

Provision for the recycling of rainwater or 'grey' water should be integrated into all schemes.

Measures to maximise energy efficiency and reduce CO₂ emissions of new buildings will be encouraged.

The Council recommend that development proposals are designed to be forward thinking in their approach to energy and power generation.

Developers are strongly encouraged to include solutions such as photovoltaic panels and solar panels or design buildings in a way where future households can accommodate renewable energy measures in the future.

Provision of ground source heat pumps (gshp) for heating internal spaces and water will also be encouraged. Where gshp are not technically viable, air source heat pumps could be used.

Further resources

[Urban Air Quality, Woodland Trust, 2012](#)

[Air pollution: outdoor air quality and health \(Draft 2016\) \(final version expected June 2017\)](#)

Architectural terminology

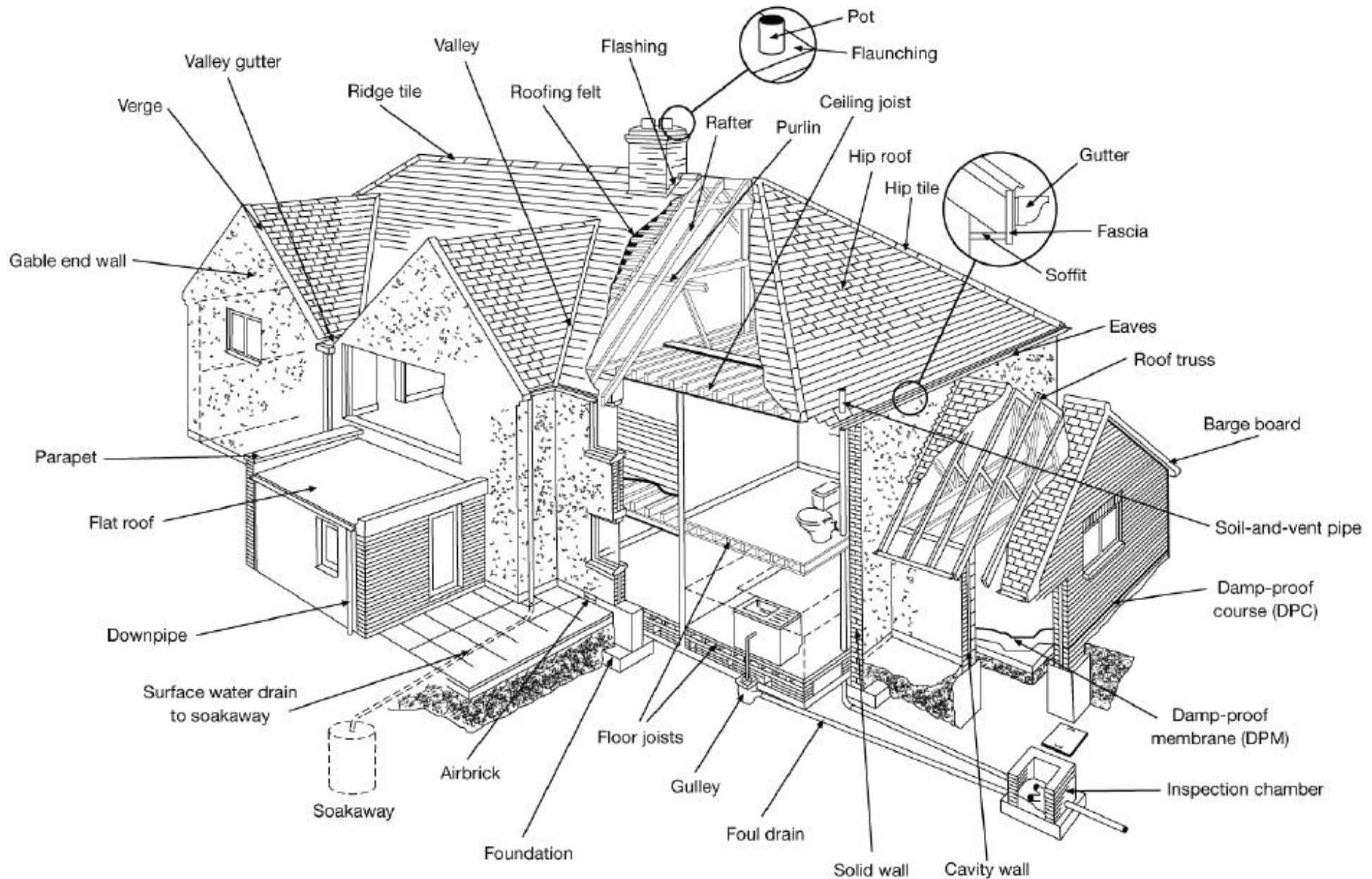

References

- 1) Official Police Security Initiative (2016) Secured by Design Homes 2016
- 2) Department for Transport (2008) Local Transport Note 1/08, Traffic management and streetscape
- 3) Department for Transport (2011) Local Transport Note 1/11 Shared Space
- 4) Department for Transport (2007) Manual for Streets, HMSO
- 5) Department for Transport (2010) Manual for Streets 2, HMSO
- 6) Leicestershire County Council (updated 2013) 6 C's Design Guide (available on Leicestershire County Council 's website (and future updated versions of this guide);
- 7) Sustrans (2014) Sustrans Design Manual Handbook for cycle-friendly design
- 8) please see <http://www.20splenty.org>
- 9) South Derbyshire District Council (2016) Open space, sport and community facility strategy 2016
- 10) Chris Goodman, Habinteg Housing Association (2011) Lifetime Homes Design Guide (IHS BRE) www.lifetimehomes.org.uk
- 11) Derbyshire County Council (2014) Landscape Character of Derbyshire www.derbyshire.gov.uk/environment/conservation/landscapecharacter/
- 12) Dorset AONB partnership and Hamilton-Baillie Associates, (2011) Traffic in Villages, Safety and Civility on Rural Roads
- 13) Urban Design Skills for the Homes and Communities Agency (2010) Qualityreviewer: appraising the design quality of development proposals
- 14) National Forest Design Charter www.nationalforest.org/document/information/design_charter.pdf
- 15) National Forest Guide for Developers and Planners www.nationalforest.org/woodlands/woodlandcreation/development/
- 16) Cowan, R (2003) Urban Design Guidance (Thomas Telford)
- 17) Sport England (2015) Active Design: Planning for health and wellbeing through sport and physical activity
- 18) Public Health England (2014) Everybody active everyday
- 19) Birbeck D and Kruczkowski S (2016) Building for Life 12 (Nottingham Trent University: CADBE for the Building for Life Partnership) www.builtforlifehomes.org
- 20) McGinnes JM, Williams-Russo P, Knickman JR: The case for more active policy attention to health promotion, Health Aff (Millwood) 2002; 21(2) 78-93
- 21) Adapted from McGinnis JM et al (2002) above within Health and Urban Design presentation by Lucy Saunders, TfL on www.urbannous.org.uk

Appendices

Appendix A

Extending your home

The Council aims to ensure that extensions are in keeping with the main dwelling and the general character of the area and avoid unreasonable impact on the living conditions of the occupiers of nearby dwellings.

In some cases planning permission will not be needed to extend your home. You can find out more about this on the [Planning Portal](#) or you apply for a formal [Certificate of Lawfulness](#).

It is a good idea to use a person qualified and experienced in designing residential extensions as there are [National Requirements](#) for every planning application. In addition there may be [Local Information Requirements](#) depending on the nature and location of the proposal. These are [South Derbyshire's Local Requirements](#)

Once you have obtained permission you may need to address other legal issues, for example [Building Regulations](#) , [Party Walls Act](#) and private covenants and obligations.

Appearance

With such a wide variety of types of house and layout in the environment there can be no hard and fast rule about how an extension should be designed. This can only be decided by careful examination of a particular building and its surroundings. Special considerations apply to listed buildings and conservation areas and "Historic South Derbyshire" (a further publication available from the Planning Office) will be used to consider the design of proposals affecting these. Outside settlements the Council will try and make sure that the impact on the countryside is minimal - this can mean that an extension is not as large as you may wish it to be.

For all applications, the following four points will be looked at:

1. Scale

What an extension looks like can have an important impact on the character of an area. As a general principle it is a good idea to ensure that an extension looks like a smaller part of the main dwelling, in a way that the main part of the building is not overpowered by it. This becomes particularly important when the main dwelling displays the traditional local distinctiveness of South Derbyshire. However, it is possible to gain a lot of extra space by designing the extension so that it looks smaller than it actually is.

For example instead of a large extension to the side of a house, a smaller side extension and a rear extension could be used to achieve a similar amount of space.



An example of a sympathetic extension

2. Character and Form

When extending it is usually necessary to reflect the existing character, form and proportion of buildings.

This means paying careful attention to gable widths, roof form, angles of roof pitches, the pattern and detailing of window and door openings, eaves and verges and any other particular detailed characteristic of the house.

The fine detailing of an extension can be crucial in fitting in with the main building. Where streets have an obvious character (e.g. Victorian and interwar streets) it will be particularly important to ensure careful attention to detail.

In more modern housing estates, where dwellings are not all the same, there can be more flexibility, but the general principles set out above will still be looked at. In some cases, for example in a street of houses set at regular intervals, care will need to be taken when extending to the side to avoid a 'terraced effect'.

In order to protect the character of non-terraced streets and to ensure that extensions are subordinate in scale and do not result in a terracing effect, two storey and first floor side extensions should be set back at first floor level from the front wall of the original house by a minimum of 1 metre, and have a lower ridge line than the existing property.

Two storey and first floor side extensions can have a significant impact on the street scene. The reduction in width or sometimes the total loss of space between properties can often create a 'terracing effect' where two properties join to create the impression of a continuous building frontage.

Example image only

Diagram to be re-drawn



3. Position

The front of a dwelling is generally the most sensitive to alteration. Extensions here may not always be acceptable, particularly where there is an obvious 'building line'. Where an extension is acceptable, the Council will look very carefully at the features that make up the main building, especially roof pitches, window patterns and other architectural details.

Side extensions can also have a significant effect on what a building will look like. Where side extensions are acceptable, particularly if higher than single storey, care should be taken to make sure that they complement and sit comfortably alongside the main dwelling. The complete structure (main dwelling and extension) should be assessed as a new building in its own right and should be no less attractive than the main dwelling was originally, and ideally be an improvement in appearance. Attractiveness and appearance are assessed on factors such as: style, detailing, scale, height, massing, proportion, order, symmetry, materials, relationship to adjacent properties, relationship with the wider streetscape and the rhythm of

frontages.

In some cases, for example at the end of a terrace, the best design solution may be to add an extension at the same height and width as the terrace. Rear extensions should present fewer problems, but two-storey extensions in particular, should not upset the basic shape and design of the house.

Roof extensions will normally be very noticeable and in some cases may not be acceptable. Small roof dormers with pitched roofs set well below the ridge generally look better because they are less likely to harm the character of a building. Roof extensions to the rear are likely to be more acceptable but must still be in keeping with the building. Flat roofs on two storey extensions will not normally be allowed.

4. Materials

The use of the right materials is very important and the Council will usually require that materials match the existing building or will want to see samples for approval. Sometimes, for example where an existing building has been rendered, it may be better to use

materials that do not match, although it is usually a good idea to find materials that have similar colour, size and texture. Setting an extension in reveal to existing walls can help to reduce the visual impact of a slight mis-match in materials.

Effect on Neighbours

The effect of an extension on neighbours often causes most concern. Because one person's idea of what is acceptable is not necessarily the same as another's, the Council has written guidelines to be fair to both sides, although it is always necessary to consider proposals on their own merits.

Normally, extensions that meet the guidelines will be acceptable. The main issues that concern neighbours are overlooking (or loss of privacy) and overshadowing (or overbearing).

In order to protect the occupiers of neighbouring dwellings from overlooking and to protect privacy,

the 'primary' windows of the neighbouring dwellings should not fall within the minimum distance (as set out in the table overleaf) within the sector of

view of the 'primary' windows of the proposed extension.

These guidelines will be applied on the particular merits of the situation but not to side and 'secondary' windows to either property as this would be likely to result in those applying being unfairly disadvantaged.

Where the view between windows can be prevented (e.g. by a screen wall or fence of reasonable height) then the minimum distances may be reduced. Shrubs and trees are not normally reliable as a screen because they may not always be there.

In order to protect windows in neighbouring dwellings from overshadowing, proposed two-storey extensions should not breach the minimum distance (set out in the Distance Guidelines table) along a 45° line drawn from the centre of the nearest ground floor 'primary' window of the neighbouring property. Single storey extensions will be decided on their own merits.

Distance Guidelines

NEIGHBOURING DWELLING

All distances in metres

P R O P O S E D D W E L L I N G O R E X T E N S I O N		Lounge/dining room	Kitchen	Bedroom/study (first floor)	Bedroom/study (ground floor)	Conservatory
	Lounge/dining room	21	21	15	18	21
	Kitchen	21	21	15	18	21
	Bedroom/study (first floor)	21	21	15	18	21
	Bedroom/study (ground floor)	18	18	12	15	18
	Conservatory	21	21	15	18	21
	Blank elevation	12	12	No minimum	9	9

The guidelines assume that sites are relatively level, with little or no screening and normal ground floor and first floor layouts. The guidance also assumes straightforward identification of front, rear and side elevations.

Where situations arise that do not readily fit these guidelines, decisions will be made on the merits of the case. For example, full height first floor windows can exacerbate overlooking.

Although most houses overlook neighbouring rear gardens to some extent, areas closest to main windows are where occupants most value privacy. The impact of new development on such private outdoor areas will therefore be assessed on the merits of each case. Balconies serving upper floors will usually create unacceptable overlooking and should be avoided unless they can be effectively screened, or are well away from neighbours.

Sometimes, rear gardens of existing dwellings will be of such a depth that the distances between dwellings will be met regardless of how close to the boundary an opposing new property would be sited. In these circumstances, the presence of first floor primary windows in the new dwelling could lead to a significant loss of privacy to the entire private space of the existing property. In such cases, the Council will seek to ensure that the proposed dwelling is located a reasonable distance from the garden boundary of the existing dwelling.

guidance within section 8 – Make parking comfortable within the Street Design, Movement and Legibility section to find out what constitutes a parking space in a garage.

Variations may be considered due to location (such as town centre sites).

Please see the latest version of the 6C's Design Guide⁶ for further guidance on parking provision.

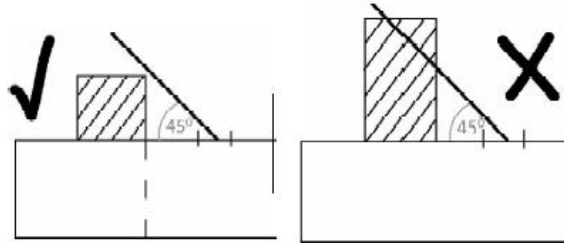

Access and parking

When looking at proposals for extensions, the Council will try and make sure that there is enough parking at the property. The advice below can be applied to all residential developments.

The Council strongly encourages two spaces per dwelling.

For homes of four bedrooms or more, it is recommended that three spaces are provided.

For flats, it is recommended that one unallocated visitor space is provided for every two dwellings (half a space per dwelling).

These spaces should ideally be in addition to any garage provision. See the Garage size rules and design

Where elevations are opposite each other, separated by public areas, such as a road, and having regard to the overall character of the surrounding area, the guidelines will usually be relaxed.

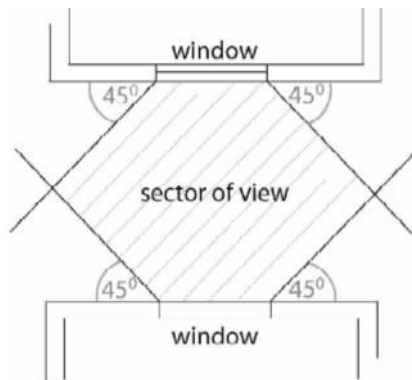

Appendix B

Checklist for site and contextual analysis

a) Record the general impressions of the site:

For example, existing sense of place. Use notes, sketches, plans, photographs to record information including legibility.

b) Record site's physical characteristics:

For example, site dimensions/area, features, boundaries, slopes, ground conditions, drainage, water resources, trees and vegetation, ecology, buildings and other features.

c) Examine relationship between site and surroundings:

For example, land uses, roads and footpaths, public transport nodes and routes, local facilities and services and other infrastructure.

d) Consider environmental factors affecting the site:

For example, orientation, sunlight/daylight, climate, microclimate, prevailing winds, shade/shelter, exposure, pollution, noise, fumes,

smells.

e) Assess visual and spatial characteristics:

For example, views, vistas, panoramas, attractive features or buildings, eyesores, quality of townscape and surrounding space, landmarks, edges, nodes, gateways and spatial sequences.

f) Observe human behaviour:

For example, desire lines, general atmosphere, gathering places and activity centres.

g) Consider the area's background and history:

For example, local and regional materials, traditions, styles, details, prevailing architectural and urban design context, urban grain and archaeological significance.

h) Assess existing mix of uses:

For example, variety, on site, around site, contribution to vitality.

i) Research statutory and legal constraints:

For example, ownerships, rights of way, planning status, planning conditions, covenants, statutory undertaker's services.

j) SWOT analysis

SWOT: Strengths, Weaknesses, Opportunities and Threats.

k) Note any danger signals:

For example, incompatible activities or adjacent uses, sense of security.

Source: Chapman and Larkham (1994) from Carmona, M. et al, 'Public Places, Urban Spaces' (2003), pp. 244.

Appendix C

Relationship between the District Council’s Design Principles (Policy BNE1) and National policies, initiatives and guidance documents

SDDC Design Principles	NPPF (Department of Communities and Local Government, 2012)	Building for Life 12¹⁹	National Forest Design Charter¹⁴	By Design (DETR, 2000) Seven objectives of urban design	Urban Design Compendium (Llewelyn-Davies, English Partnerships, 2000)	Active Design (2015)¹⁷
Community safety	58, 69	7	People focused	Continuity and enclosure	Places for People	2, 6
Street Design, Movement and legibility	9, 17, 35, 38, 39, 41, 58, 61, 69, 75	1, 3, 8, 9, 2 (indirectly)	Legibility and connectivity Accessibility	Ease of movement Legibility Quality of the public realm	Make connections	2, 3, 6
Diversity and Community Cohesion	9, 17, 38, 47, 50, 69, 70	4	Inspiring places	Diversity	Mix uses and form	1, 4, 6, 7
Ease of use	35, 39, 57, 58, 69	10, 11, 12	People focused Landscape design Integrated design Sustainable	Adaptability	Design for change Manage the investment	1, 5, 6, 7, 9
Local character and pride	9, 10, 17, 56, 58, 59, 60, 61, 64, 109	5, 6	Creating a forest identity and setting Distinctive character Inspiring places Landscape and ecological design	Character	Enrich the existing Work with the landscape	

Visual attractiveness	9, 17, 58, 59, 63, 64, 118	5, 7, 11	Inspiring places Landscape and ecological design	Quality of the public realm	Places for people Enrich the existing	6
National Forest	9, 17, 58, 60, 109, 117, 118, 123, 125	5, 6, 11	all	Quality of the public realm Character	Work with the landscape Enrich the existing	3, 5, 7
Neighbouring uses and amenity	17, 123, 124, 125	6, 12				
Cross boundary collaboration	17, 31, 70, 117, 178, 179, 180, 181	1, 6	Legibility and connectivity	Ease of movement	Make connections	3
Healthy Lifestyles	7, 8, 9, 17, 38, 69, 70, 73, 74, 171, 178	1, 2, 3, 4, 6, 8, 9, 11, 12	Sustainable Building greener Building innovation Achieving national excellence	Legibility Quality of the public realm Diversity	Places for people Make connections Mix uses Work with landscape	All
Resource Use	7, 17, 94, 95, 97					

BfL 12 Criteria

- 1: Connections
- 2: Facilities and services
- 3: Public transport
- 4: Meeting local housing requirements
- 5: Character
- 6: Working with the site and its context

- 7: Creating well defined streets and spaces
- 8: Easy to find your way around
- 9: Streets for all
- 10: Car parking
- 11: Public and private spaces
- 12: External storage and amenity space

10 Active Design Principles

- 1. Activity for all
- 2. Walkable communities
- 3. Connected walking & cycling routes
- 4. Co-location of community facilities
- 5. Network of multifunctional open space
- 6. High quality streets & spaces

- 7. Appropriate infrastructure
- 8. Active buildings
- 9. Management, maintenance, monitoring & evaluation
- 10. Activity promotion & local champions

Appendix D — Lifetime Homes 16 Criteria

Lifetime Homes guidelines

To encourage the construction of homes that are accessible to everybody and where the layout can easily be adapted to meet the needs of future occupants.

Criterion 1 – Parking (width or widening capability) Principle: Provide, or enable by cost effective adaptation, parking that makes getting into and out of the vehicle as convenient as possible for the widest range of people (including those with reduced mobility and/or those with children).

Criterion 2 – Approach to dwelling from parking (distance, gradients and widths) Principle: Enable convenient movement between the vehicle and dwelling for the widest range of people, including those with reduced mobility and/or those carrying children or shopping.

Criterion 3 – Approach to all entrances Principle: Enable, as far as practicable, convenient movement along other approach routes to dwellings (in addition to the principal approach from a vehicle required by Criterion 2) for the widest range of people.

Criterion 4 – Entrances Principle: Enable ease of use of all entrances for the widest range of people.

Criterion 5 – Communal stairs and lifts Principle: Enable access to dwellings above the entrance level to as many people as possible.

Criterion 6 – Internal doorways and hallways Principle: Enable convenient movement in hallways and through doorways.

Criterion 7 – Circulation Space Principle: Enable convenient movement in rooms for as many people as possible.

Criterion 8 – Entrance level living space Principle: Provide accessible socialising space for visitors less able to use stairs.

Criterion 9 – Potential for entrance level bed-space Principle: Provide

space for a member of the household to sleep on the entrance level if they are temporarily unable to use stairs (e.g. after a hip operation).

Criterion 10 – Entrance level WC and shower drainage Principle: Provide an accessible WC and potential showering facilities for: i) any member of the household using the temporary entrance level bed space of Criterion 9, and: ii) visitors unable to use stairs.

Criterion 11 - WC and bathroom walls Principle: Ensure future provision of grab rails is possible, to assist with independent use of WC and bathroom facilities.

Criterion 12 – Stairs and potential through-floor lift in dwellings Principle: Enable access to storeys above the entrance level for the widest range of households.

Criterion 13 – Potential for fitting of hoists and bedroom / bathroom relationship Principle: Assist with independent living by enabling convenient movement between bedroom and bathroom facilities for a wide range of people.

Criterion 14 – Bathrooms Principle: Provide an accessible bathroom that has ease of access to its facilities from the outset and potential for simple adaptation to provide for different needs in the future.

Criterion 15 – Glazing and window handle heights Principle: Enable people to have a reasonable line of sight from a seated position in the living room and to use at least one window for ventilation in each room.

Criterion 16 – Location of service controls Principle: Locate regularly used service controls, or those needed in an emergency, so that they are usable by a wide range of household members - including those with restricted movement and limited reach.

Appendix E

The Landscape character of Derbyshire

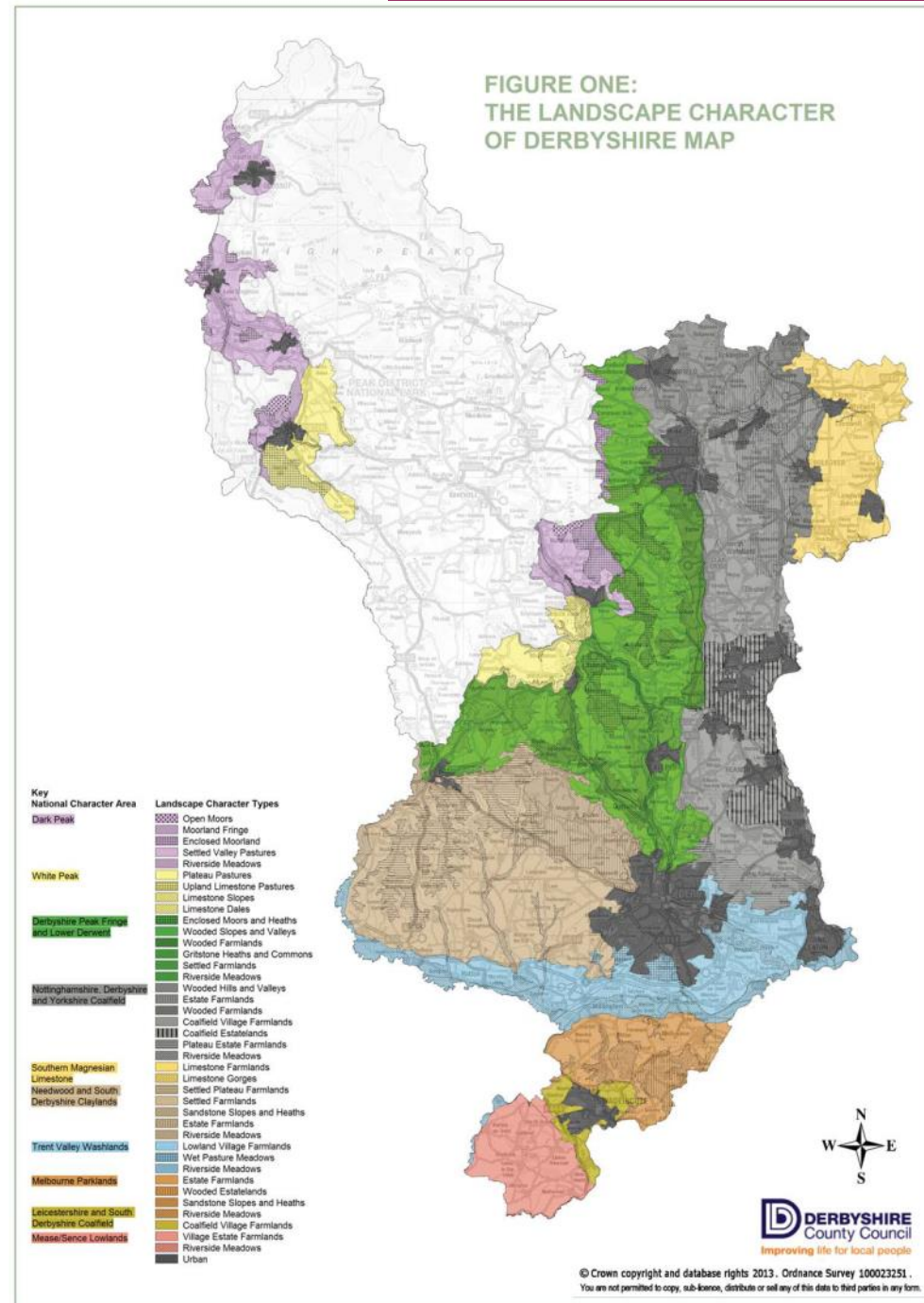

Appendix F

Justification of the need to address air pollution

Air pollution

Air pollution is the largest contributor to the burden of disease from the environment that can impact on the whole population. Current evidence indicates that air pollution is associated with cardiovascular disease, lung cancer, respiratory disease, asthma and stroke. Air pollution disproportionately affects the young, older people, those with underlying cardiopulmonary conditions and the most deprived within our communities.

Risks are mainly related to long-term exposure to particulate air pollution (PM_{2.5}) and nitrogen dioxide (NO₂). Nitrogen dioxide (NO₂) is produced with nitric oxide (NO) during the combustion of fossil fuels. Together they are often referred to as oxides of nitrogen (NO_x). The evidence associating NO₂ with health effects has strengthened substantially in recent years. There is increasing evidence that links long-term exposure to NO₂ to mortality, although it is possible that, to some extent, NO₂ acts as a marker of the effects of other traffic-related pollutants.

Particulate matter (PM) is an air pollutant which contains a mixture of microscopic solid and liquid particles suspended in air. It is made of various physical and chemical components such as nitrates, sulphates, ammonium and other inorganic ions; organic and elemental carbon; polycyclic aromatic hydrocarbons (PAHs); metals such as copper, zinc and nickel; dust, soil and smoke. Biological

components such as allergens and microbial compounds are also found in PM. The commonly used definition of PM refers to the mass concentration of particles with a specified diameter. PM with a diameter of 10µm or less referred to as PM₁₀ and particles with a diameter 2.5µm or less are referred to as PM_{2.5}. PM also includes ultrafine particles which have a diameter of less than 0.1µm.

Similarly, there will be a health burden from short-term exposure to some air pollutants (e.g. ozone) although this impact is likely to be less. Other pollutants of less concern, in terms of their typical concentration in the air that we breathe, include benzene (C₆H₆), sulphur dioxide (SO₂), carbon monoxide (CO), lead (Pb) and 1,3-butadiene.

The financial implications arising from the health burden associated with air pollution are considerable. DEFRA have estimated the annual health costs for UK citizens to be in the region of £15 billion (range: £8-17 billion). As a comparison the health costs arising from obesity have been estimated to be around £10 billion per year. There is, however, relatively low public awareness of air quality as an issue, making air pollution an invisible public health problem that affects much of the UK.

The primary sources of particulate and nitrogen dioxide are illustrated in Figure 1 below.

Actions that improve local air quality can deliver public health benefits across entire local authority

areas. There are no thresholds of effect identified for nitrogen dioxide and particulate matter and therefore health benefits can be expected from improving air quality even below concentrations stipulated by air quality standards. This means that action to improve air quality is not just about dealing with areas where there are exceedances of air quality standards.

There is growing evidence that tackling air pollution can be a key element of growth and regeneration policies. Town centres can benefit in many different ways from measures that reduce air pollution potentially including reduction of noise pollution and surface temperature, increased amenity value, and improved aesthetic appearance. Further to this these measures improve health outcomes and reduce health inequalities in a cost-effective way that promotes healthy and active lifestyles, therefore leading to social and economic benefits. Spatial planning has an important role to play in improving air quality and reducing people's exposure to air pollution. New urban developments can be designed to improve local air quality and the health of the local population by considering the placement of transport and industrial infrastructure, better street design to encourage community cohesion and better use of innovative building design.

Figure 1: Primary Sources of oxides of nitrogen (NOx) and fine particulate matter (PM2.5)

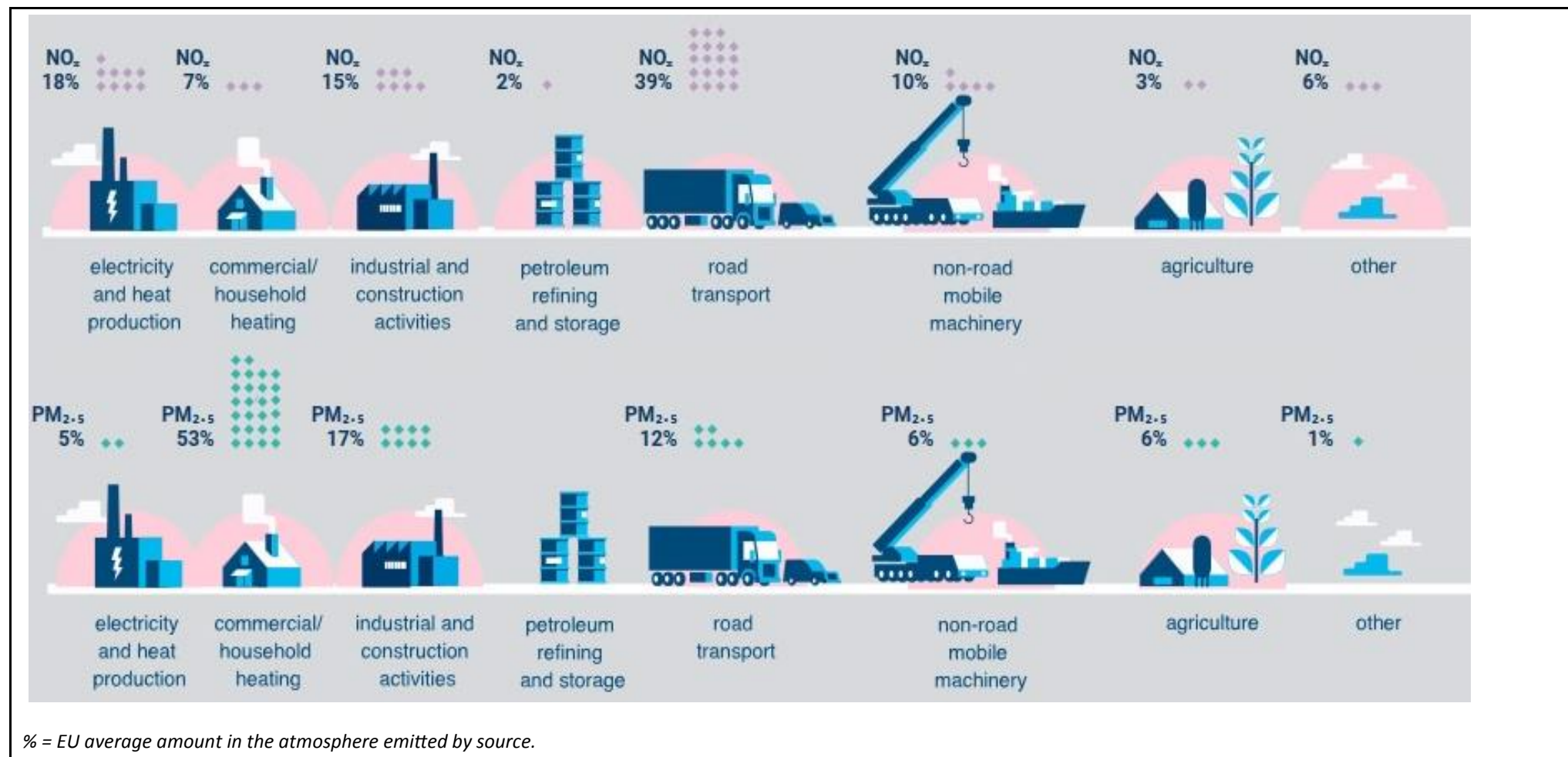

Air Pollution and Public Health

In England, the mortality burden of exposure to particulate air pollution arising from human activities is estimated as an annual effect equivalent to 25,000 deaths, with an associated loss of life of 265,000 years¹. For the East Midlands it has been estimated as an annual effect equivalent to 2,314 deaths, with an associated loss of life of 24,016 life-

years attributable to particulate air pollution. In South Derbyshire the estimated impact is 42 deaths per annum and loss of 439 life years.

Public Health England publishes an annual indicator in the Public Health Outcome Framework relating to air quality. The indicator is a summary measure of the impact on death rates of long term exposure to man-made particulate air pollution. The indicator underlines the scale of the health impact and the

fact that it is modifiable. PHE estimates of the mortality burden are based on modelled annual average concentrations of fine particulate matter (PM_{2.5}) in each local authority area originating from human activities, based on the attributable mortality in 2010¹. These estimates are useful when assessing local public health priorities, as well as to those working in the field of air quality and public health.

Table 6: Public Health Outcome Framework indicators which can be positively affected by air quality interventions³⁴

1.10 (PHOF)	Rate of people killed and seriously injured on the roads, all ages, per 100,000 resident population
1.16 (PHOF)	Percentage of people using outdoor space for exercise/health reasons
2.06i (PHOF)	Percentage of children aged 4-5 classified as overweight or obese
2.06ii(PHOF)	Percentage of children aged 10-11 classified as overweight or obese
2.12 (PHOF)	Percentage of adults classified as overweight or obese
2.13i (PHOF)	Percentage of adults achieving at least 150 minutes of physical activity per week in accordance with UK CMO recommended guidelines on physical activity
3.01 (PHOF)	Fraction of all-cause adult mortality attributable to longterm exposure to current levels of anthropogenic particulate air pollution
3.06 (PHOF)	Percentage of NHS organisations with a board approved sustainable development management plan
4.04i (PHOF)	Age-standardised rate of mortality from all cardiovascular diseases (including heart disease and stroke) in persons less than 75 years of age per 100,000 population
4.07i (PHOF)	Age-standardised rate of mortality from respiratory disease in persons less than 75 years per 100,000 population
2.3i and 2.3ii (NHS OF)	Reducing time spent in hospital by people with long-term conditions i Unplanned hospitalisation for chronic ambulatory care sensitive conditions (adults) ii Unplanned hospitalisation for asthma, diabetes and epilepsy in under 19s

There are a range of evidence-based and achievable actions which improve air quality and health outcomes. Action can be taken at a number of levels and, in some cases, air quality initiatives significantly complement programmes to increase physical activity, decrease obesity and improve cardiovascular and respiratory health.

Air Pollution and Deprivation

Areas of poor air quality are often linked to areas of deprivation. Low income tenants, owner occupiers or those in social housing tend to occupy homes near to main transport routes and built up areas where house prices are lower. Improving air quality in these areas will lead to significant reductions in

health inequality.

Air Pollution and Sustainable Economic Growth

It is recognised that new development will in the main inherently increase road transport emissions, both during the construction and operational phases. However, it is also recognised that sustainable development can be a positive force for change. The approach in this document seeks to minimise or offset road transport emissions by designing in emission mitigation while retaining or enhancing the value of development proposals.

¹ Committee on the Medical Effects of Air Pollutants (COMEAP) - Statement on the evidence for the effects of nitrogen dioxide on health. Available at <https://>

www.gov.uk/government/publications/nitrogen-dioxide-health-effects-of-exposure

[outcomes-framework#page/3/gid/1000043/pat/6/par/E12000004/ati/102/are/E06000015/iid/30101/age/230/sex/4](https://www.kingsfund.org.uk/sites/files/kf/field/field_publication_file/improving-the-publics-health-kingsfund-dec13.pdf)

² World Health Organisation (WHO) - Health Effects of Particulate Matter. Available at http://www.euro.who.int/_data/assets/pdf_file/0006/189051/Health-effects-of-particulate-matter-final-Eng.pdf

⁸ The Kings Fund - Improving the public's health: A resource for local authorities. Available at https://www.kingsfund.org.uk/sites/files/kf/field/field_publication_file/improving-the-publics-health-kingsfund-dec13.pdf

³ Committee on the Medical Effects of Air Pollutants (COMEAP) - Long-term exposure to air pollution: effect on mortality (final report - June 2009). Available at https://www.gov.uk/government/uploads/system/uploads/attachment_data/file/304667/COMEAP_long_term_exposure_to_air_pollution.pdf

⁴ Department for Environment, Food and Rural Affairs - Air Pollution: Action in a Changing Climate (2010). Available at https://www.gov.uk/government/uploads/system/uploads/attachment_data/file/69340/pb13378-air-pollution.pdf [Accessed 26/07/16].

⁵ European Environment Agency - Cleaner air for all http://ec.europa.eu/environment/air/cleaner_air/

⁶ World Health Organization (WHO) Regional Office for Europe. Review of evidence on health aspects of air pollution - REVIHAAP Project: Final technical report 2013 15/10/14. Available from: <http://www.euro.who.int/en/health-topics/environment-and-health/air-quality/publications/2013/review-of-evidence-on-health-aspects-of-air-pollution-revihaap-project-final-technical-report>

⁷ Department of Health. Public Health Outcomes Framework 2013 to 2016, last updated 2015. Available at <http://www.phoutcomes.info/public-health->

Appendix G

Historic South Derbyshire

HISTORIC SOUTH DERBYSHIRE



Conservation Areas, Listed Buildings
Houses, Barns, Warehouses,
Shops, Advertisements

Design Advice

Contents:	Page No.
PURPOSE OF THE GUIDANCE	102
SOUTH DERBYSHIRE'S HERITAGE	103
LOCAL BUILDING MATERIALS TRADITIONAL CONSTRUCTION AGRICULTURAL BUILDINGS SHOP FRONTS	
CONSERVATION AREAS	110
MAKING AN APPLICATION DESIGN GUIDANCE	
LISTED BUILDINGS	120
MAKING AN APPLICATION DESIGN GUIDANCE	
CONVERSION OF HISTORIC AGRICULTURAL BULDINGS	124
MAKING AN APPLICATION DESIGN GUIDANCE	
CONVERSION OF HISTORIC INDUSTRIAL BUILDINGS	
SHOP FRONTS AND ADVERTISEMENTS	129
MAKING AN APPLICATION DESIGN GUIDANCE	

Purpose of the Guidance

This supplementary planning document is based on South Derbyshire Local Plan Policies S1 (v), BNE1, BNE2 & BNE10. It provides guidance for applicants seeking consents for works affecting heritage assets, in particular conservation areas and listed historic buildings. Further information about the district's heritage assets can be found on the [Council's website](#). The government's [Planning Practice Guidance](#) explains how the law and planning policy affect the historic environment.

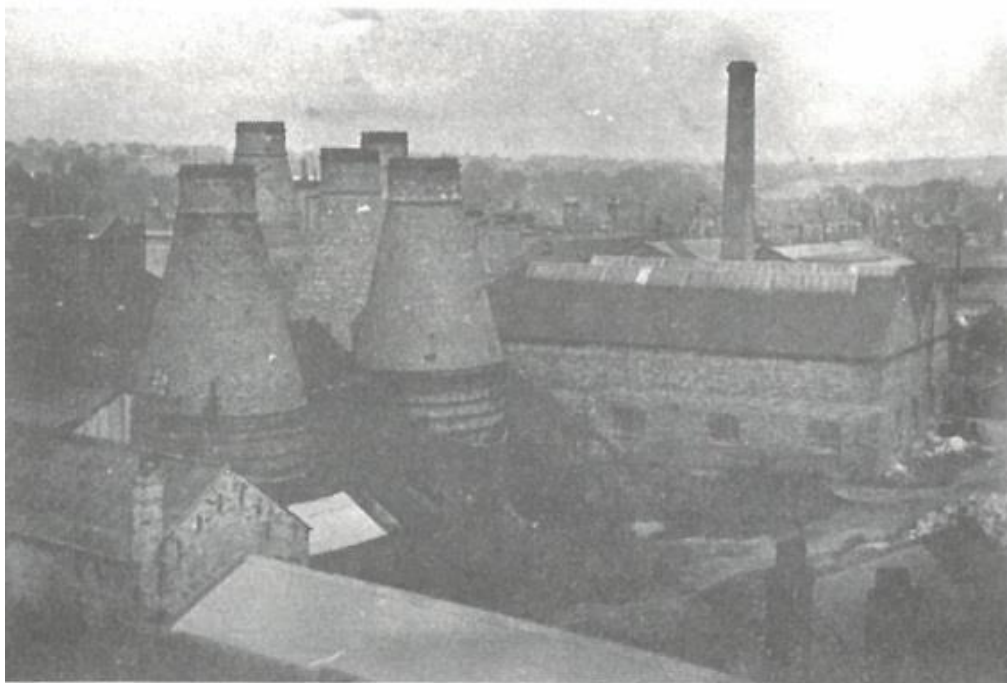

Bottle Kilns, now demolished, at Sharpes Pottery, Swadlincote
Photographed in about 1950

South Derbyshire's Heritage

The District has a large number of buildings and settlements of historic and architectural interest spanning many centuries, and has important examples of most periods and many types of architecture: from the Anglo-Saxon crypt at Repton Church, through to the nineteenth century bottle kilns of the pottery industry: from the inland canal port at Shardlow to the tranquil rural settlements of the Trent Valley. Any reference to South Derbyshire's heritage would be incomplete without a mention of such assets as the National Trust owned Calke Abbey, with its estate village of Ticknall, and the medieval settlement of Melbourne, which is a microcosm of architectural development from Norman times to the present day.

Through all this variety there is an underlying unity, which transcends time and style, and which comes through the use of natural local materials taken or manufactured from the land and through traditional forms of construction. Thus the District has its own distinctive and cohesive traditional character - the local vernacular.

LOCAL BUILDING MATERIALS

Historically transport was difficult and expensive. Labour however was cheap and building materials close to hand. Because materials were not transported but picked up or dug out of the ground close to the construction site vernacular buildings appear to grow out of the landscape and really seem to belong.

The geology of Derbyshire is extremely varied and a large number of variations occur here in a small area in the south. Not surprisingly this gives rise to a varied vernacular tradition of stone, brick and timber framed buildings. The most common materials however, with a proven track record of durability are BRICK and PLAIN CLAY TILES. The Alluvium and Keuper Marl deposits are the largest and it is these which have, historically, rendered suitable clays for brick and tile making. In some areas, like Melbourne and Stanton by Bridge, bands of good quality STONE occur (in this instance Millstone Grit) which have been used in quantity though not to the exclusion of brick. The Millstone Grit is usually used as random rubble though it is also found carefully coursed with a decorative hand tooled finish. Also outcropping around the District are Keuper, Bunter and Coal Measures Sandstones. None of these stones have been used extensively and apart from for churches and grand houses their use is confined to "dressings" such as cills and lintels on brick buildings and to boundary walls. At Ticknall limestone outcrops. This was burnt to create quicklime, the precursor of modern Portland Cement, for building purposes. A small number of TIMBER FRAMED buildings survive throughout the District with origins as early as the 14th and 15th centuries. Infill panels are variously of wattle and daub, lath and plaster, and plastered clay tiles or slabs of stone. Although they would once have been the most common form of vernacular building, the majority of those surviving today, would have been the quality buildings of their time. Vestiges of earlier timber framed buildings can be found in many which have since been rebuilt or refaced in brick. RENDER is not commonly used in the District though there are some examples. Heavily textured wet dash render, a common local tradition in some areas, is rare here and where it does exist it looks out of place. There are however some elegant stuccoed buildings from the Regency and other periods. Stucco is a smooth render made from a lime based mix. The top coat is finished with a wood float which gives a slight texture to the flat surface. Often the final coat is "lined out" to represent stone work. The rendered west elevation of Calke Abbey is a good example of this.



Calke Abbey. 16th and 17th century, remodelled in 1702. Rendered west elevation to the left.



Church of St. Andrew, Twyford.



No. 1 Mill Shardlow, an early 19th century canal warehouse.

BRICKS have been made in the District for centuries. The earliest known surviving bricks are those used to construct Prior Overtons Tower at Repton in about 1440. These would have been made on the spot from locally dug clay. Brickmaking was still quite primitive at this time and its use was quite a rarity. Bricks began to be made on a larger scale in the 17th century and really took off in the 18th and 19th centuries. Early bricks are thin; 50-60 mm. By the beginning of the nineteenth century they had become bigger with courses typically of 75 mm. Local bricks are basically red with subtle colour variations of dark grey, blue, purple, brown and yellow. It is this variation which gives them their distinctive character.

PLAIN CLAY TILES cover the roofs of buildings of all different ages throughout the District. The earliest are red and handmade. These are cambered through their length and width and are irregular in shape giving a typically bumpy texture to a roof. The more regular machine made tile, whilst it still has a camber, results in a roof with a less marked texture. Handmade tiles, both red and blue, still survive in considerable numbers though the machine made blue tiles of the 19th century,

which are very durable, are the most common. In the late 18th and 19th centuries natural SLATE which was then being transported into the District by canal and rail became more common. A few examples of THATCH, the antecedent of all other roof coverings, survive. Of course the examples we see today are not in themselves ancient (a thatched roof has a life of only about sixty years) but are the most recent replacement of the original roof covering.

LEAD has been used in building from early times both as a roof covering and for lining gutters and forming downpipes, which are to be found on grand rather than modest buildings. The earliest gutters were probably of timber though the writer knows of only one surviving example. Thatched roofs would have had no gutters but CAST IRON proved the most durable for tiled and slate roofs. Windows and doors are almost universally of painted TIMBER made from local hardwoods and dense softwoods which are of better quality than woods used in modern joinery. There are some examples of metal windows.

TRADITIONAL CONSTRUCTION

The unity in materials is related to the proximity of the raw materials. Unity in construction is related to the physical capabilities of people, and the innate qualities of the material being used. For instance lengths of readily available timber for roof structures restricts gable widths to a maximum of about twenty feet. For a plain clay tiled roof to be waterproof it has to be reasonably steep with a minimum pitch of about 40°. For thatch to keep the water out an even steeper pitch is necessary. Bricks and tiles are manufactured to sizes which are easy to handle. Stone too is worked to manageable sizes. To make a brick wall strong the bricks are laid to a bond and many variations exist. Flemish bond and random bonds are most common on South Derbyshire's vernacular buildings. Small paned windows were so because glass could only be produced in small pieces. In Georgian times glazing bars (the horizontal and vertical pieces of timber which held the panes of glass in place) were very slender, between 15 mm and 18 mm, in order to make the most of the light despite the small panes. Generally the later the building the larger the panes of glass. Plate glass was first available in about 1860 and from then on larger shop windows with fewer subdivisions begin to appear.

Characteristically vernacular houses are two and three storey, of simple rectangular shape with pitched roofs. Larger buildings tend to be made up of additional ranges of similar shape.

The eaves and verges of vernacular buildings are distinctively different to their modern counterparts. White painted soffit and fascia boards and unadorned flush barge boards stand out and look incongruous in an historic setting. Projecting bands of decorative brickwork or moulded stonework with cast iron gutters sometimes ogee shaped, fixed with metal brackets are traditional. Many 19th century buildings display an attractive contrast in their decorative overhanging barge boards. These are typical on small dormer windows of the same period often with carved finials. White painted, small paned, timber windows are a dominant characteristic of South Derbyshire. They contrast with, enliven and stand out against walls of dark red brick. The majority are vertically sliding sashes, horizontally sliding sashes or side hung casements. Agricultural buildings have distinctive window types sometimes unglazed or only partially glazed. Segmental brick arches over doors and windows are common as are stone lintels of various types. Stone and brick cills are common.



Potter Street, Melbourne. 16th century timber frame.



Coursed Millstone Grit with decorative tooled surface.



Melbourne Tythe Barn. A mixture of brick, stone, machine made and hand made plain clay tiles.

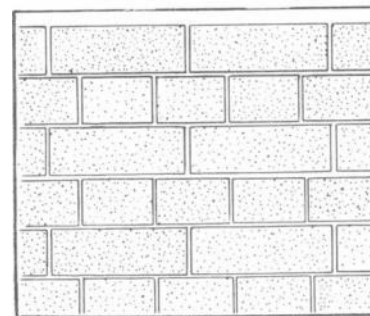

English brick bond.

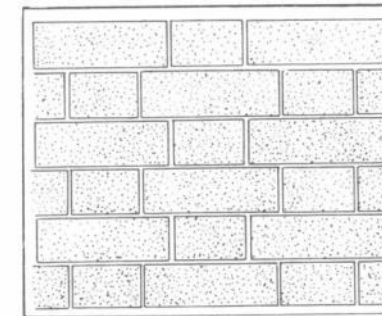

Flemish brick bond.

Many modest buildings have timber lintels and no cills. Glazing bars are usually moulded and slender and individual panes of glass are invariably longer than they are wide giving traditional windows an elegant vertical proportion. Traditional doors are usually boarded or panelled. An authentic panelled door has a much deeper bottom rail and mid (or lock) rail than its modern counterpart.

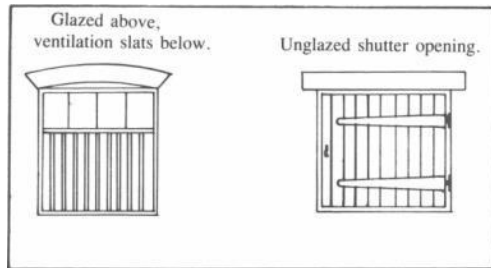

Traditional agricultural openings

AGRICULTURAL BUILDINGS

Much of the foregoing description applies to agricultural buildings but there are significant differences between these and other traditional buildings which deserve a few additional words of explanation. Many are single storey, others which are similar to other two storey buildings in height are open to the roof. As there is no upper floor or ceiling their roof structures are clearly open to view. Whilst some are subdivided internally others may be completely open. The type, pattern and number of openings are quite different to those in domestic buildings. There may be doors at first floor level, originally intended for loading straw and grain for winter storage. There may be large opposing doors extending through the full height of the building, originally designed to provide a natural draught for threshing grain. Other openings may vary in size and be randomly placed. The total number of openings is usually small, the ratio of solid wall to opening being quite high. Some elevations will be completely solid, uninterrupted by openings of any kind. The joinery is quite different to domestic buildings. Doors are usually simple boarded. Stable doors have the familiar central split. Windows are often unglazed with a solid boarded shutter, some partially glazed with ventilation slats, and some which are completely glazed open like hoppers, that is hinged at the bottom to drop inwards. Oils of any kind are uncommon and lintels are usually timber or simple segmental brick arches. Ventilation was important in agricultural buildings whether for animals or grain. "Breathers", small slits or other small openings often arranged in a decorative pattern, are quite common.



Former threshing barn, now a restaurant at Calke Abbey. Notice the 'breathers' on either side of the large doorway.



Agricultural buildings in Ticknall. Walls and roofs uninterrupted by openings.

SHOP FRONTS

The traditional shop fronts which survive in South Derbyshire are 18th, 19th and early 20th century, largely of painted timber, some incorporating decorative detail in cast iron, glazed brick and ornamental tiles. These shop fronts are based on a set of principles, derived from classical architecture which result in an attractive and rational link with the building as a whole. They look solid and able to support the walls above and are generally subdivided into bays which echo the rhythm of the building above and adjacent. Their various elements include cornice, fascia, pilasters and stall riser. Collectively they frame the shop window and individually each has a function. The cornice projects at the top and provides protection from the weather. The fascia beneath it provides a taylor made space for painting 'on a sign. There may also be a painted timber sign hanging from a wrought or cast iron bracket. The stall riser gives protection at the base. The pilasters may provide (or hide) structural support or can be purely decorative. The result may be plain, elegant or intricately ornamental. Invariably they are well proportioned and designed to suit the building they serve. As a rule earlier shop fronts have an upright fascia with plain ends and later shop fronts have fascias inclined forwards with consoles at the ends. In either case the fascias are rarely deeper than 375 mm. (15"). They are usually of painted timber although the cornice, fascia and pilasters can be formed in brick or stone. Stall risers are variously painted timber, glazed brick, decorative tiles or, especially where the shop front is a later insertion, red brick. In Swadlincote town centre there are a number of first floor shop windows from the early 20th century. The majority of conservation areas contain at least one local shop. Etwall, Repton, Melbourne and Swadlincote contain groups of shops. The two latter settlements have discernible town centres with Swadlincote being the largest commercial centre in the District.



Early 20th century shop front with curved glass and cast iron mullions in Swadlincote.



Late 19th century shop front with glazed tiling at Melbourne.

The foregoing is by no means a comprehensive description of South Derbyshire's vernacular buildings, but includes their most common and distinctive characteristics, which can be seen throughout the District and especially in conservation areas and listed buildings.



The alignment, scale and massing of these new houses in Melbourne and Stanton by Bridge harmonises well with their historic setting.



Conservation Areas

In conservation areas there are additional planning controls that affect works to buildings and other structures. Permission is required for demolition (called ‘Relevant Demolition’) or part demolition of most buildings and structures, with limited exceptions. In addition, it is necessary to give notice of works to trees in conservation areas. It is very important to note that unauthorised works to trees or Relevant Demolition constitute an offence that could result in prosecution.

In Shardlow, Melbourne, Ticknall Article 4 Directions are in place. These directions mean that planning permission is needed for most alterations and extensions, including replacement windows and doors. To find out if your property is affected by an Article 4 Direction see the Council's website. In Twyford an Article 4 Direction makes it necessary to apply for planning permission for all agricultural buildings.

More information about Permitted Development rights and Article 4 Directions in conservation areas can be found in the Planning Practice Guidance website.

MAKING A PLANNING APPLICATION

Planning applications are usually submitted by appropriately qualified and experienced agents but the Planning Practice Guidance provides detailed information on how to make an application. Any application will need to provide sufficient information to enable the Council to address the statutory considerations of the Planning (Listed Buildings and Conservation Areas) Act 1990 (see in particular sections 16, 66 and 72) as well as satisfying the relevant policies within the National Planning Policy Framework and the Local Plan. The Planning Practice Guidance explains the information needed before the Council can validate an application.

Typical traditional additions which respect the scale and form of the original building.

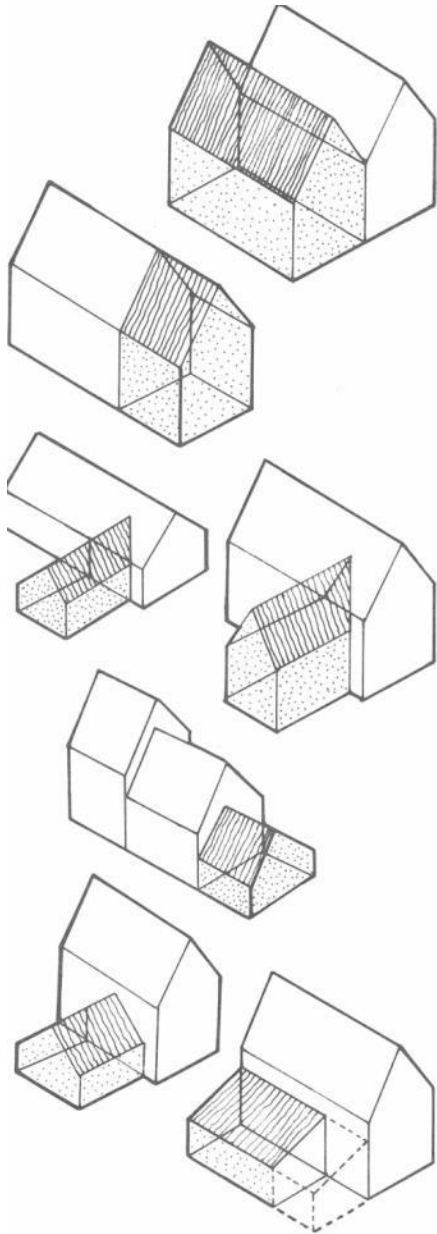

Bad pointing will disfigure and damage old bricks and stone.

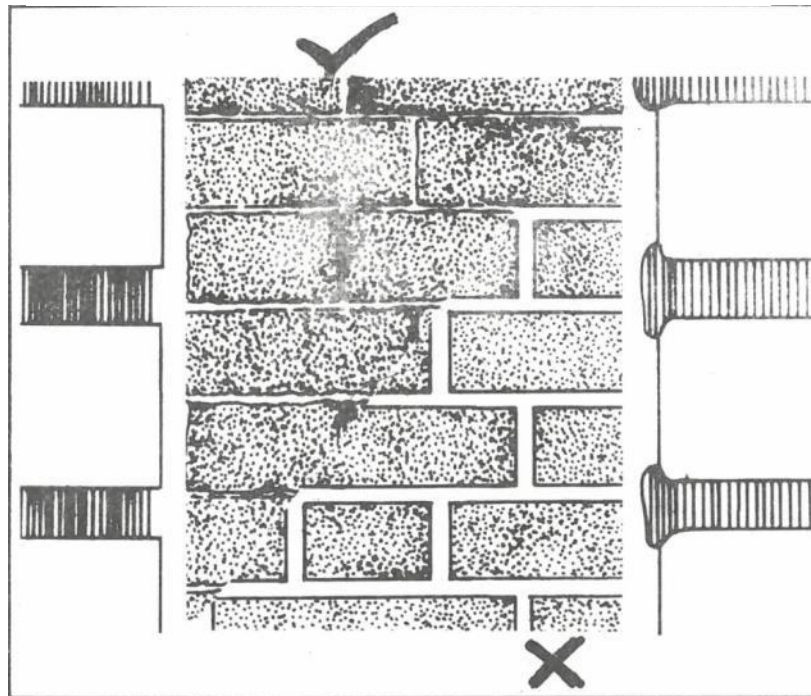

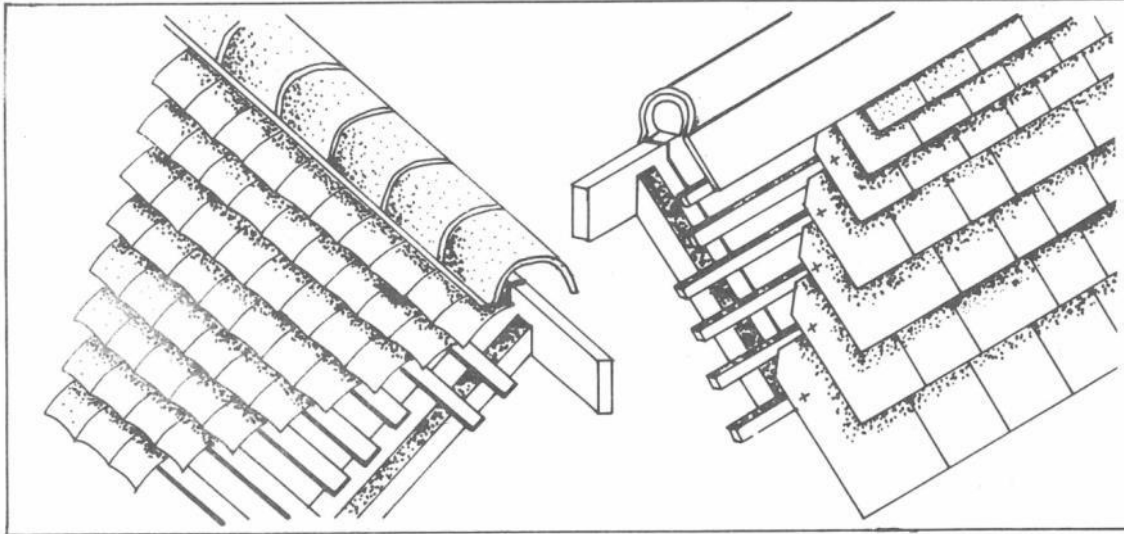

Plain clay tiles need a roof pitch of 40°

Natural slate laid to diminishing courses. An economical way to use hand riven (split) slate.

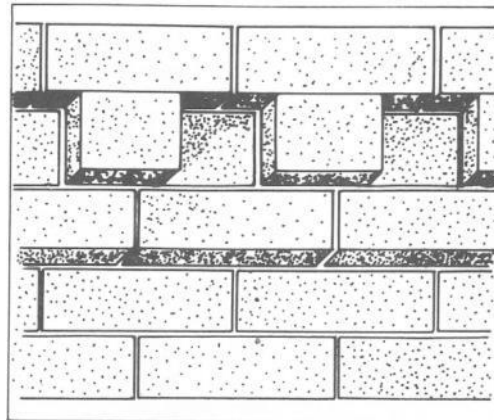
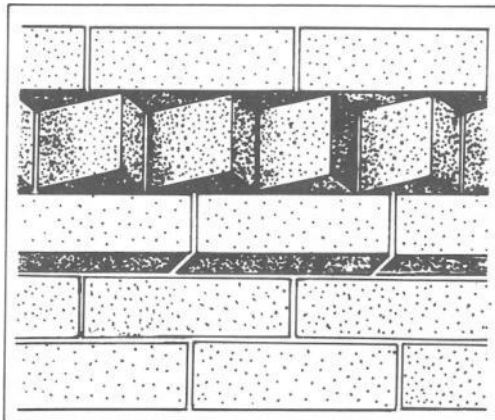

Projecting decorative brickwork

Typical South Derbyshire eaves details.

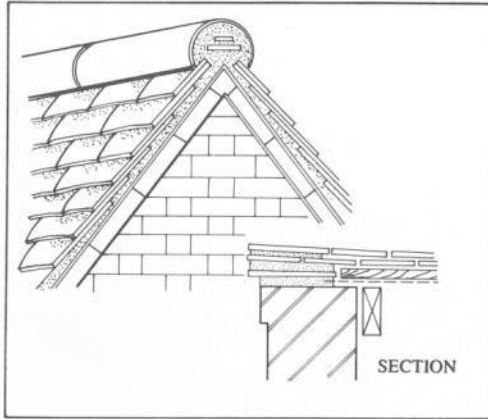

A typical South Derbyshire verge with projecting brick band

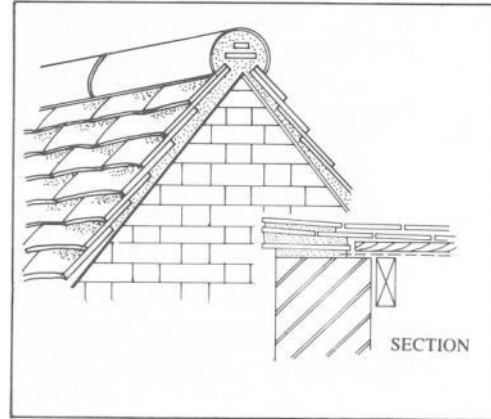

A typical plain verge

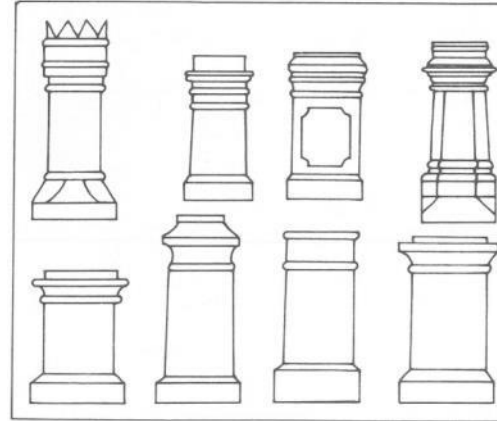

There are hundreds of different patterns of clay chimney pots. Many are still made today.

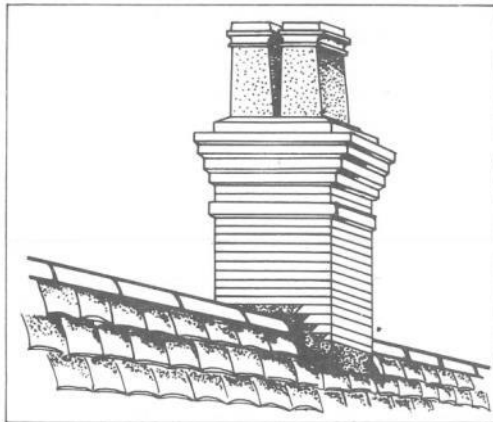

Oversailing courses look attractive and throw rainwater off the chimney stack.

DESIGN GUIDANCE

It is not the intention of the Council to stifle good design by the application of a rigid set of rules. The following guidelines are most suited to domestic and other small scale developments though they may be applied more generally. Exceptions may be acceptable but this will depend upon the quality of the overall design.

1. **SITING AND ALIGNMENT.** Historic settlements derive their character not only from buildings but from the spaces and enclosures which those buildings create through their relationship to one and another. For a new development to look like it belongs it must maintain or strengthen the established pattern, and should not disrupt or block important views or encroach on important areas of open space. Standard suburban housing layouts will seldom suit a conservation area setting. Layouts where houses form groups, give a sense of enclosure and variety in height and density will be more appropriate. Following an established pattern could mean setting a building at right angles to a road, or maintaining a tightly built up frontage. It may be best to locate a building on low ground or where it will be screened by existing trees.
2. **SCALE AND MASSING.** Careful consideration should be given to the shape and size of a new building. The following rules of thumb are suggested. Aim for a minimum roof pitch of about 40° and a maximum gable width of about 7 metres. Make sure the height and overall size of the building(s) is similar to those in the vicinity. The apparent size of a large building can be reduced by breaking it down into a number of elements; a main 2 storey range, a lower 2 storey or single storey range at right angles and perhaps another single storey lean to. "L" shaped and "T" shaped buildings are preferable to those with a square or near square plan. Similarly a new building with variations in height may be more easily assimilated into an historic setting. Extensions will usually be more successful if they are visually subordinate to the buildings to which they are attached. This can be achieved by setting the extension back from the main building, lowering its ridge and eaves line and reducing its width. Sometimes a contrasting traditional building material and a slight change in architectural style, in both cases to something more modest, will be appropriate. The acceptability of an extension will be considered both in terms of its effect on the building to which it is to be attached and the effect on the character of the conservation area. Where the existing building is traditional but has been altered unsympathetically or where the existing building is not traditional the effect on the conservation area may be a more important consideration.
3. **MATERIALS.** The importance of local materials in creating a sense of belonging cannot be too strongly emphasised. Using sympathetic materials for new development is essential. Although building materials are no longer made "on the spot" modern manufacturers offer a wide range of suitable natural materials.
 - i) **BRICK.** Second hand brick may be best for repairs and some extensions but there are plenty of acceptable new bricks being produced to give a reasonable choice for new developments. A red brick which displays a variation in colour will normally be best.
 - ii) **STONE.** In some areas the use of stone may be appropriate. Boundary walls are commonly built of stone even where the majority of buildings are brick. Second hand or new stone may be used but it should be geologically similar to that used in the area and it must be employed in a traditional manner. In some instances random rubble will be appropriate and in others dressed, coursed stone. Stone is no longer quarried in the District but suitable stones can still be obtained from elsewhere in Derbyshire and further afield. A leaflet giving details of suppliers is available from the Directorate of Community and Planning Services.

iii) **POINTING.** It is essential that stone and brickwork are pointed and repointed appropriately. A LIME mortar should be used, no stronger than 1: 1:6 (cement:lime:sand). Finished joints should be slightly recessed leaving a clean edge to bricks and stone and the mortar brushed to give it a textured surface. Leaflets giving detailed guidance are available from the Directorate of Planning and Economic Development.

iv) **RENDER.** Is not commonly used in the district and will rarely be appropriate for new buildings.

v) **PLAIN CLAY TILES.** Second hand or new tiles may be used. Most often blue clay tiles will be appropriate although in some locations red clay tiles may be more suitable. Machine made and hand-made tiles are still manufactured. Concrete equivalents will not be permitted.

vi) **SLATE,** This may be new or second hand, but must be natural slate. Artificial, manufactured 'slate' will not be permitted.

4. **DETAILED DESIGN.** Traditional buildings are peppered with small decorative details which are both functional and attractive. Historic towns are like huge reference libraries from which details can be copied and with skill and imagination can successfully be adapted and developed.

i) **EAVES AND VERGES.** Modern white painted flush barge boards and fascia boards and the ubiquitous grey plastic gutter are singularly unattractive especially in an historic setting and should be avoided. Cast metal gutters should be used, fixed direct to the walls on metal brackets. Projecting courses of bricks at the eaves will give added interest. Verges should be plain or may have a projecting brick string course. Projecting rafters along the eaves line and overhanging verges may also be appropriate.

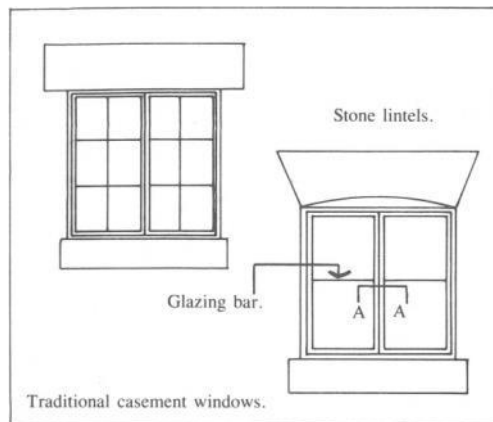

Traditional window patterns

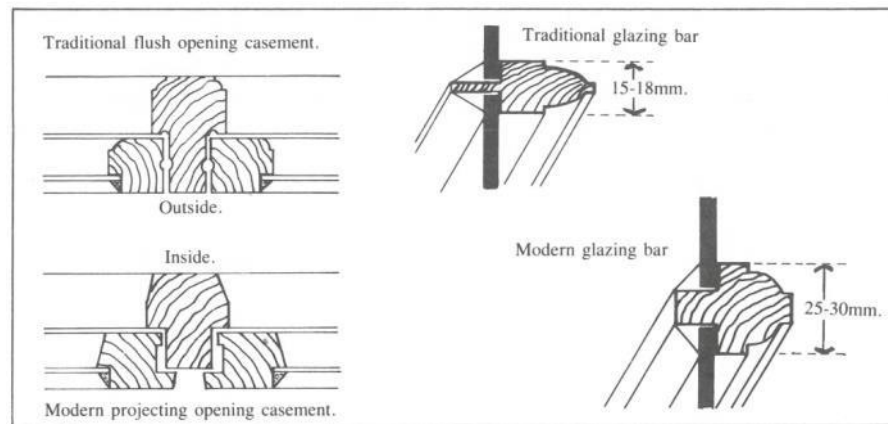

Section AA.

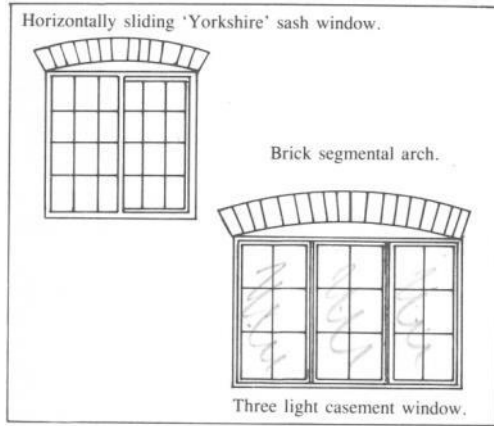

Traditional window patterns

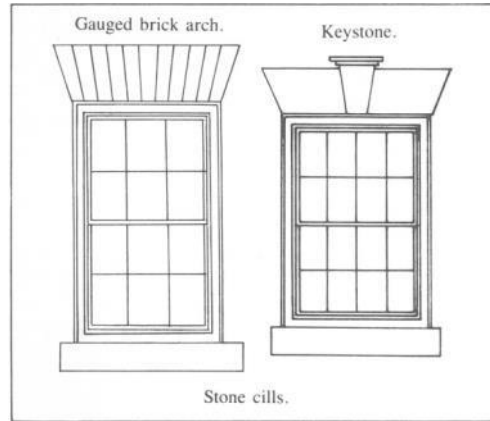

Georgian sliding sash windows.

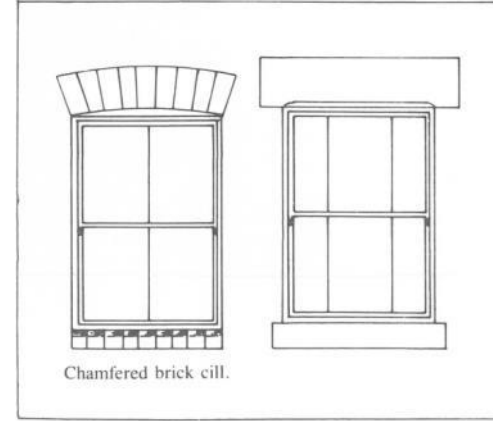

Victorian sliding sash windows.

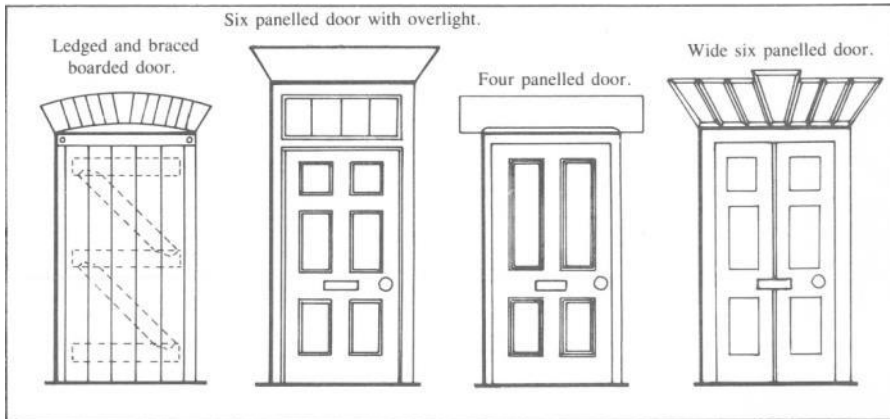

Traditional door patterns

- ii) CHIMNEY STACKS. Should generally be on the ridgeline of the roof and should not project beyond external walls. Stacks should have traditional oversailing courses. Without them they look weak and will not throw off rainwater as efficiently. Clay pots will also improve their appearance.
- iii) EXTERNAL JOINERY. Should be PAINTED TIMBER. This is such a strong local characteristic that stained timber, aluminium and UPVC windows and doors will not normally be permitted. An appropriate traditional style should be used. Side hung casements, vertically sliding sashes and horizontally sliding sashes are all suitable. If small paned windows are to be used then the glass must be puttied not beaded and the overall width of glazing bars must be no greater than 18mm. Sealed double glazing units cannot be manufactured in this way. Therefore glazing bars must be omitted altogether where sealed double glazed units are to be used or where small panes are required they must be single glazed. Secondary glazing can of course be provided in such cases. Casement windows should be traditionally constructed so that opening casements are flush with the frame or set back from the frame. Windows should be set back with a traditional form of cill and lintel. Modern "storm proofed" windows with an integral timber cill will not be permitted.

Plain boarded and panelled doors are suitable. Panelled doors may be part glazed with CLEAR glass. There are numerous variations within these two basic types of door and the style chosen should suit the style and status of the building and its location.

Windows and doors which differ from established traditional styles may be acceptable where they form part of an integrated design of high quality. This will rarely be appropriate on small scale developments.

Where it is appropriate in principle detailed drawings, including sections which fully illustrate the proposal will be required.

Given continuing advances in joinery manufacturing techniques all cases will be assessed on their particular merits, having regard to the Local Plan and national policy on heritage assets.

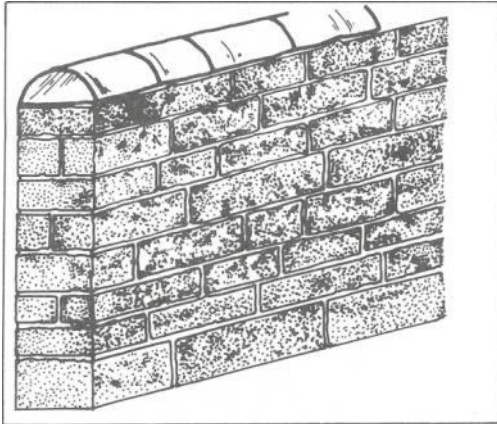

Traditional coursed stone boundary wall with half round stone coping.



Traditional cast iron railings and gate.

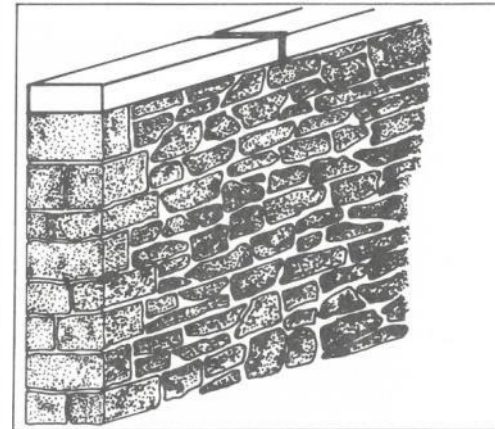

Traditional random rubble stone wall with deep flat stone coping.

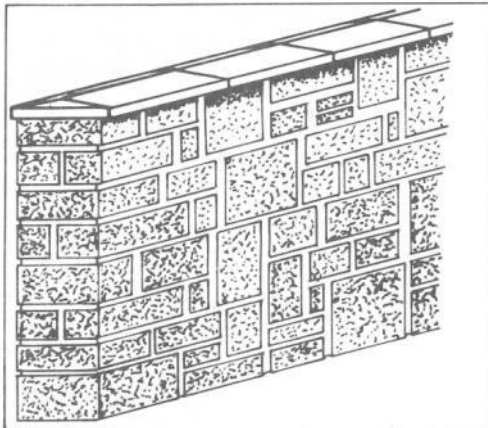

Ugly sneaked artificial stone and concrete copings cannot compare with an authentic traditional boundary wall.

- iv) **SERVICES.** These should be provided unobtrusively. For example services such as soil and vent pipes, electricity and gas meters and sink wastes can easily be provided internally, and this usually avoids unnecessary disfiguration of new and renovated buildings alike. Heating and ventilation flue outlets can be provided unobtrusively by using low profile and flush fittings.
- (v) **WALLS, GATES AND FENCES.** These should be of a kind traditionally used in the locality. Brick and stone walls are common. It is essential that these should have a traditional coping. Timber and iron gates are typical. It is important that these should be of a traditional style which is suited to its location.
- vi) **VEHICULAR ACCESS AND PARKING.** It can be difficult to accommodate the motor car without causing damage to historic settlements, but its impact can be minimised. In some instances it will simply not be possible to provide additional vehicular access or large areas of parking. The use of gardens or other spaces, which contribute to the character of the conservation area as car parks will generally be resisted. Where a new access is acceptable the location must be carefully chosen and the width of the access kept to a minimum. Boundary walls must be finished in a sensitive way where a gap is formed. Turning provision must be provided in as unobtrusive a manner as possible avoiding large expanses of visible tarmac.
- vii) **SATELLITE DISHES AND SOLAR PANELS.** Satellite dishes and solar panels, especially in proliferation, are unsightly in an historic setting. Where planning permission is required will only be granted where dishes and panels can be located where they do not have a detrimental effect on the character and appearance of the conservation area.



All kinds of structures are listed. The Market Cross at Repton is Listed Grade I. It has a 17th century shaft but dates back to medieval times.

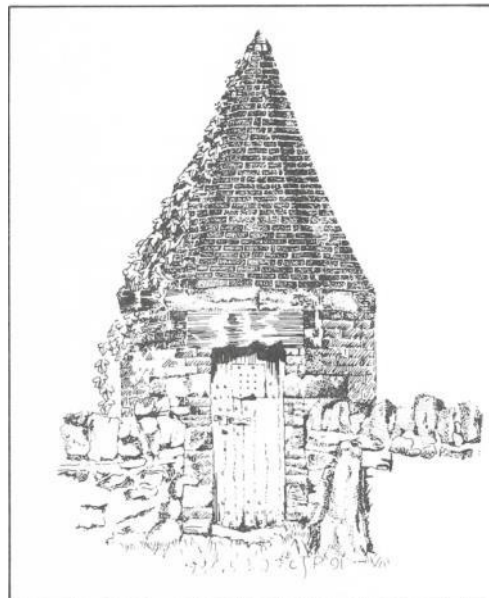

This late 18th century lock up 'in Ticknall is listed Grade II*.



Ticknall arch (1794) which once carried a tramway is listed Grade H.

Listed Buildings

Listed Building Consent (LBC) is required for the demolition, partial demolition, alteration or extension of a listed building and any structure attached to it ,or within its curtilage: You will for instance need LBC to make a new window opening, change a door, change a roof covering, add a porch, paint brick or stonework, remove paint or to alter even a low boundary wall. LBC must be obtained in addition to planning permission and building regulation approval which is required in the normal way.

It is not just the front elevation of a listed building that matters. The same controls apply for alterations to the rear or inside. You will for instance need LBC to render a back wall, to remove a fireplace or alter a staircase. If you are planning any work it is best to check with the Council on the need for consent.

Unauthorised work can lead to prosecution and the Council may take enforcement action requiring the work to be 'undone'.

MAKING A PLANNING OR LISTED BUILDING CONSENT (LBC) APPLICATION.

Planning and Listed Building Consent applications are usually submitted by appropriately qualified and experienced agents but the Planning Practice Guidance (PPG) provides detailed information on [how to make an application](#). Specific guidance on applications for [Listed Building Consent](#) is also available in the PPG. Any application will need to provide sufficient information to enable the Council to address the statutory considerations of the Planning (Listed Buildings and Conservation Areas) Act 1990 (see in particular sections 16, 66 and 72) as well as satisfying the relevant policies within the National Planning Policy Framework and the Local Plan. The Planning Practice Guidance explains the information needed before the Council can [validate](#) an application. For all Listed Building Consent applications a [Design and Access Statement](#) must be submitted.

DESIGN GUIDANCE

The best use for a listed building will be that for which it was originally designed and built. Conservative repair and regular maintenance will be all that is needed to enable the majority to continue to serve a useful purpose. However, a listed building must not be regarded as a museum piece and with care it can usually be upgraded and adapted to modern usage with little damage to its historic fabric and with little or no change in its setting. Where a listed building becomes redundant for its intended purpose its survival will depend upon a suitable new use being found. Conversion to a new use must be carried out in a sympathetic way if there is to be any point in saving the building. The acceptability of a scheme of conversion will be assessed in terms of the threat to the building as it exists; its viability before and after conversion; and both the degree and effect of any alteration, extension or demolition involved. Schemes of conversion which have a substantial harmful effect on the historic and architectural character of a listed building or its setting will normally be refused.

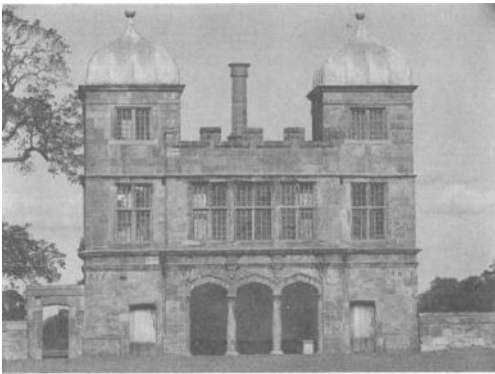

Swarkestone Stand (Listed Grade I), carefully restored by the Landmark Trust.



Rebuilding the front of this Grade II Listed Building has been avoided by using steel supports and straps which are largely concealed

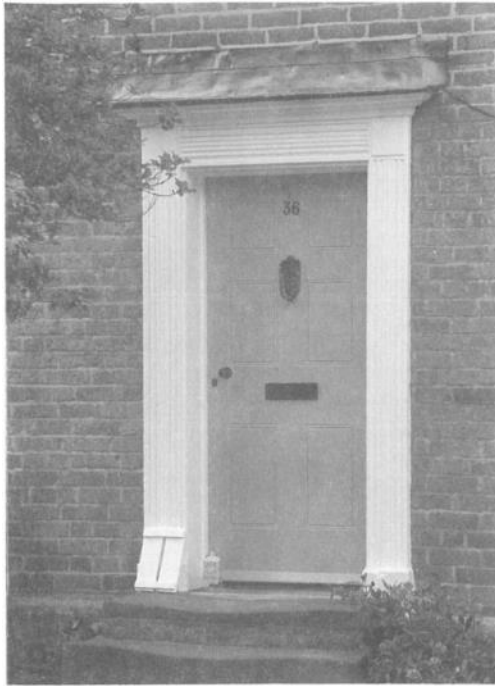

Six panelled door and timber doorcase on a Grade II Listed Building. Note the panels are flush with a simple scratch moulding. The bottom rail and the middle or lock rail are very deep.

Much of the guidance for buildings in conservation areas will apply with the following additions:

1. **PARTIAL DEMOLITION.** There is of course a presumption against the demolition or partial demolition of listed buildings. Partial demolition may sometimes be acceptable where for instance an incongruous modern addition is to be removed or original detailing is to be accurately restored. Non destructive methods of repair such as tying and strapping are to be preferred to demolition and rebuilding. Consent will only be given for such demolition where the need for the work is supported by a report from a qualified structural engineer and where the Council shares the view that this is the best method of repair.
2. **EXTENSIONS.** In some instances it will not be possible to extend a listed building at all without harming its character and such applications will be refused.

Where an extension is acceptable in principal it is most important that it should be visually subordinate and designed in a sympathetic manner, (see page no.6).

3. ALTERATIONS. Will only be permitted where:

- i) the historic form, character and structural integrity of the building is retained. .
- ii) architectural or historic elements which contribute to the special character of the building, whether part of the exterior or the interior fabric are retained intact.
- iii) new work compliments the character of the existing building in terms of design, materials, scale and detailing.

Each listed building will need to be treated on its merits. In some instances it will be necessary to achieve an exact match with existing work which may mean obtaining specialist materials. It is important that sources of supply are identified and where appropriate samples approved by the Council before any work starts on site. Advice can be obtained on sources of supply and traditional methods of repair from the Directorate of Planning and Economic Development.

4 . SATELLITE DISHES AND SOLAR PANELS. Satellite dishes and solar panels are alien and unsightly additions to historic buildings. Fitting such a receiver to a listed building will not normally be permitted. In exceptional cases it may be possible to conceal a dish from view, and where this can be done without harm to the historic fabric of the building, consent may be given. Mounting a dish or panel unobtrusively within the grounds of a listed building may be the best available option.

5 . CLEANING AND PAINTING. To paint previously unpainted brickwork and stonework will require L B C and this will only be approved where there is a proven need and the result will not have a detrimental effect on the character of the listed building. Generally such painting will be resisted. The removal of paint from brick and stonework may be desirable for aesthetic reasons but will only be approved where the method to be used does not damage the underlying material. The cleaning of a listed building may require listed building consent if this will affect its character as a building of architectural and historic interest. This will not be permitted where the cleaning damages the underlying material and consent may be refused on aesthetic grounds for instance where only one part of a terrace is to be cleaned. Because of the damage it causes sandblasting will not be permitted whether as a means of cleaning or removing paint. Similarly sandblasting will not be permitted as a means of removing paint from internal joinery and carpentry of architectural and historic interest.



Unlisted stables at Repton.

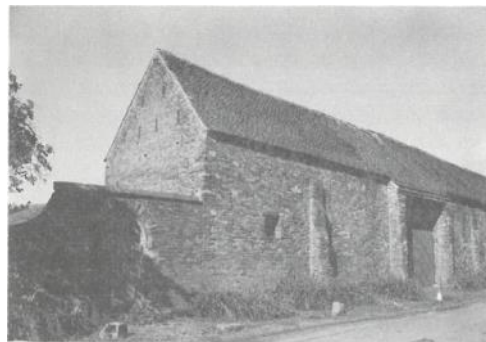

Listed Threshing Barn at Great Wilne'.



Unlisted agricultural building in Ticknall.

Conversion of Historic Agricultural Buildings

This subject has been picked out for special mention because of the scale and nature of the specific problems which it presents. Of all the possible alternative uses such buildings may be given, residential is the most damaging. Experience has shown that a residential conversion can destroy the architectural and historic interest of an agricultural building as effectively as demolition.

The very nature of some agricultural buildings will make them completely unsuited to residential use and this may be because of the type of buildings or the sensitivity of their agricultural settings, or both. Where such buildings are redundant and conversion is their only hope of survival less damaging alternatives such as workshops, offices and possibly restaurants may be more appropriate. In some cases the building may not be of sufficient quality to justify a conversion of any kind, and its ultimate loss through decay must be accepted. There will be other cases where residential use can be accommodated but only if the conversion is restricted to a small number of units. In all cases whether the buildings are listed or unlisted and whether the new use is to be residential or some other alternative, the conversion scheme will be addressed in terms of the degree of threat to the building and the desirability of its preservation. A successful scheme will accommodate the existing features of interest even if this results in unconventional living (or other) accommodation.

Where a scheme of residential conversion is granted the permitted development rights which normally apply to dwellings will be withdrawn as a condition of the approval. This means for instance that windows, doors and roof coverings cannot subsequently be changed and small extensions like porches cannot be erected without planning permission. Proposals for such subsequent changes will be considered by the same criteria as the original conversion.

MAKING A PLANNING OR LISTED BUILDING CONSENT (LBC) APPLICATION. All

applications for conversion must include accurate survey drawings including sections with truss positions clearly marked. Proposal drawings must clearly show all alterations and be annotated to show areas of repair. In most instances a full structural survey which proves that a building can be converted without substantial rebuilding may be requested before a decision is made by the Council. Plans should clearly show the position and type of existing boundaries and give details of proposed boundaries, pavings and landscaping.

Breathers. Threshing door.

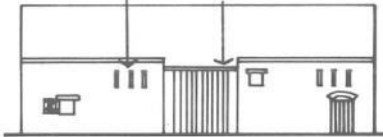

Redundant threshing barn.



Sympathetic conversion retains agricultural character.

- original openings retained.
- new openings minimal.
- 'breathers' glazed, some enlarged.
- roof unbroken.
- glazed screen to threshing door.
- services hidden inside.
- agricultural style joinery.



Agricultural character lost in this inappropriate conversion.

AVOID

- chimney stacks.
- visible/large rooflights.
- dormers.
- conservatories.
- external services.
- domestic style joinery.
- large extensions.

Top opens by dropping inwards.

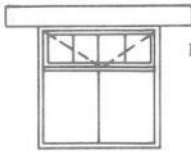

Bottom opens by dropping inwards.

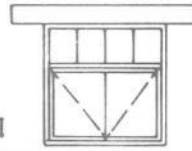

Whole window opens by dropping inwards.

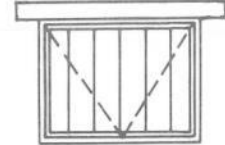

Inward opening 'Hoppers'.

Side hung casement.



Side hung casement.

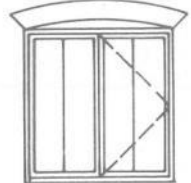

Simple glazing, shutter retained.

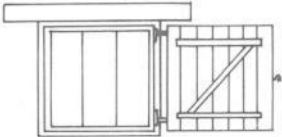

Window patterns suitable for conversions

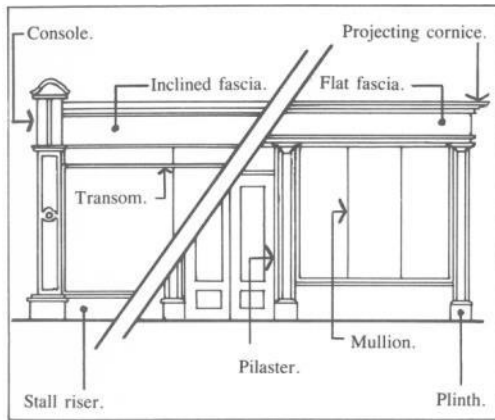

Traditional shop fronts.

DESIGN GUIDANCE

Much of the general design guidance already given in this booklet will apply.

A conversion will only be permitted where the scheme complies with the following criteria:

- 1, The conversion should not necessitate the erection of unacceptable new buildings to accommodate existing uses or contents.
- 2, The proposed use should be accommodated within the confines of the existing buildings without the need for substantial extensions or other incongruous additions such as garage blocks, An extension may be acceptable where it allows for a more sympathetic conversion of the existing building but will not be permitted where its purpose is to facilitate a high density conversion.
3. The buildings should be capable of conversion without any or with only localised minor areas of rebuilding. Where complete rebuilding is required the application will be treated as one for new development:
4. Alterations to the existing fabric should be kept to a minimum. Existing openings should be used and any new openings kept to a minimum. In the case of a residential use new openings should be restricted to the minimum required to make the building habitable. Whilst a rooflight can be a useful alternative to a new

window, a proliferation of such openings should be avoided. They should be restricted to concealed roof slopes or other unobtrusive positions and fitted flush with the roof covering. They should be restricted to the smallest size required to give adequate ventilation. 1/20th of the floor area of the room concerned will be the usual guide in assessing the need for new openings.

5. Intrusive suburban alterations such as domestic style external joinery, porches, dormer windows, brick or stone chimney stacks and external services (meter boxes, soil and vent pipes etc.) must be avoided. Windows and doors in agricultural buildings are distinctive and different to domestic styles. This must be reflected in the joinery details of the conversion.

6. Intrusive suburban alterations to the setting of the buildings such as fencing in crew yards, non traditional boundaries, non indigenous planting and excessive paving must be avoided. In countryside settings it will be important to include proposals for planting with indigenous species to help screen the development.

Conversion of Historic Industrial Buildings

Like agricultural buildings, industrial buildings do not lend themselves to residential use. The open internal spaces of these buildings, visible roof structures and immediate external setting are important elements of their character and alternative uses which can retain these features are to be preferred to residential. Of particular concern are the industrial buildings of Shardlow. Collectively they are of national importance. Some have already been converted to residential use. This inevitably results in considerable internal alterations and changes to the immediate setting of the building. If this trend continues Shardlow's special character will be seriously damaged. The Council will therefore resist further residential conversions. Only in exceptional circumstances where no other alternative is viable and the survival of the building is seriously threatened will the Council consider such applications favourably.



A modest sign is all that is needed on this eye-catching doorway.

Shop Fronts and Advertisements

Shop fronts and advertisements, by their very nature, are designed to attract attention and will therefore dominate a street and have a substantial impact on the character of historic towns and village centres. Where a shop is listed or in a conservation area planning permission or listed building consent (LBC) will only be given for development where:

- a. shop fronts worthy of preservation are retained or accurately restored;
- b. new shop fronts respect the scale, materials, colour and design of existing traditional buildings and shop fronts in the vicinity;

c. advertisements respect the character of the shop fronts and buildings to which they relate, and do not have a detrimental effect on the character of the area as a whole.

MAKING A PLANNING, CONSERVATION AREA CONSENT (CAC), LISTED BUILDING CONSENT (LBC) OR ADVERTISEMENT REGULATIONS APPLICATION. Any material alteration to the appearance of a shop (regardless of whether it is in a conservation area or listed) requires planning permission. Alterations to a shop front are clearly material. So too are such changes as replacing a traditional sash window with a modern plastic window or replacing a slate roof covering with concrete. LBC is needed for any alteration to the character of a listed building. This could include the repainting of a shop front, installing a security alarm system or extractor fan, altering the interior or installing shutters or blinds. In conservation areas CAC is needed for demolition. This would include the removal of a shop front or any features that give a building character.

The Advertisement Regulations, under which consent is needed for signs, are complex and although some signs do not need consent it is best to check first with the Council before installing one. Any advertisement on a listed building requires LBC and all illuminated signs in conservation areas whether the light source is external or internal require consent. Even where a sign does not require express consent the Council can serve a discontinuance notice requiring its removal if the sign is considered to be detrimental to the character of a conservation area or the setting of a listed building. In such cases no compensation is payable. It is wise therefore to check with the Council before installing any new sign.

DESIGN GUIDANCE

The guidance for conservation areas and listed buildings will apply with the following additions:

1. **EXISTING SHOP FRONTS OF QUALITY.** These should be kept and where repair is necessary the elements affected replaced with replicas of the existing.

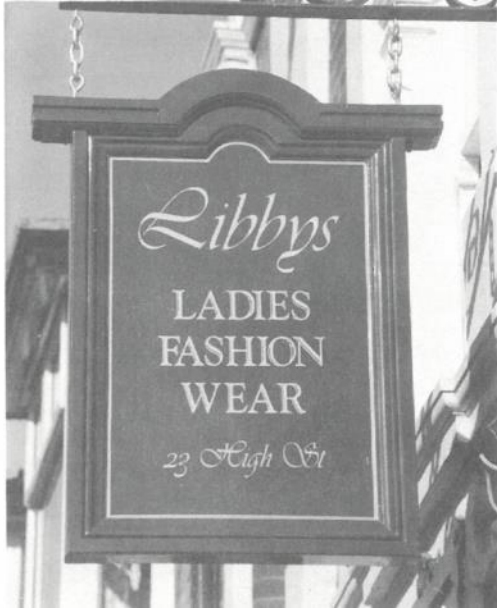

A recently installed non illuminated hanging sign.



Original light fitting to a Swadlincote shop.

2. **EXISTING SHOP FRONTS OF QUALITY WHICH HAVE BEEN SPOILED BY THE LOSS OR INAPPROPRIATE MODIFICATION OF ARCHITECTURAL DETAILS.** These should be reinstated to their original form or, where this is unknown or impractical, to a form which retains elements which survive and which is in keeping with the shop front and the building as a whole.
3. **NEW SHOP FRONTS.** Where a shop front is to be provided in a traditional building then it should be painted timber and the traditional principles of shop front design, incorporating cornice, fascia, pilasters and stall riser should generally be followed. In some cases an accurate copy of a traditional design will be appropriate. In any case the shop front should respect the rhythm of the building as a whole in terms of the door position and subdivision of the shop windows. The scale and proportion of the shop front should be in keeping with the building as a whole and suited to its location. Wide expanses of uninterrupted glass and excessively deep fascias should be avoided.

Where a shop front is incorporated in a new building, the creative interpretation of traditional principles can result in striking new designs which are modern, well-proportioned and well suited to historic locations. An alternative non-traditional approach can be successful for larger shopping developments where the shop front forms part of an integrated design of high quality. In such cases provision for signs must be built into the sign.

4. ADVERTISEMENTS. Advertisements must be designed and located so as to respect the unique character of individual areas and buildings. The number, size, shape, location, colour and detailed design will all have a bearing on this. Consequently, a proliferation of signs or signs which are overpowering will be resisted. Signs with a shiny or reflective finish will not normally be permitted. In sensitive locations it may be necessary for national organisations with a corporate identity signing system to tone down colour schemes and to produce their signs in traditional form and materials. Permission will not normally be given for internally illuminated box signs whether applied to a fascia, along a wall or projecting.

The illumination of signs is difficult to accommodate at all in a sympathetic way in historic towns and villages. Non-illuminated signs are best. Illumination of signs to public houses, restaurants and similar late opening premises will generally be acceptable, providing that the source of illumination is external and the fitting and the wiring for its installation are unobtrusive. A proliferation of lights will be resisted. In exceptional circumstances small, internally illuminated, individual letters may be acceptable.

Signs painted onto the fascia will be best for traditional shop fronts. It may also be acceptable to provide a hanging painted timber sign or to apply lettering or a logo to the glass of the shop window itself. Where there is no existing fascia any sign should relate to a shop front, being on it, in it, or directly above it. In some instances individual letters fixed direct to the building will be acceptable. In, all cases the size type and colour of lettering should suit the architectural character of the shop front and the building as a whole.



A typical grouping of traditional buildings in Melbourne. The building in the centre of the picture has unfortunately lost its original window